

DX-9100 Extended Digital Controller

DX-9100 Extended Digital Plant Controller (Including DX-912x LONWORKS, Version 3)	3
<ul style="list-style-type: none"> • <i>Introduction</i> 3 • <i>Features</i> 8 	
Installation	11
<ul style="list-style-type: none"> • <i>Version 1 (DX-9100-8154)</i> 11 • <i>Version 2 (DX-9100-8454 or FA-DX9100-8454) and Version 3 (DX-912x-8454)</i> 19 • <i>General Wiring Guidelines</i> 34 • <i>Battery Replacement</i> 35 • <i>Startup</i> 38 	
Inputs/Outputs	39
<ul style="list-style-type: none"> • <i>Analog Inputs</i> 39 • <i>Digital Inputs</i> 40 • <i>Digital Counters</i> 40 • <i>Analog Outputs</i> 40 • <i>Digital Outputs</i> 41 • <i>Analog/Digital Constants and Logic Result Status</i> 43 • <i>Extension Modules</i> 44 • <i>Network Inputs/Outputs for Version 3, LONWORKS Only</i> 46 	
Operation	49
<ul style="list-style-type: none"> • <i>Introduction</i> 49 • <i>Realtime Functions</i> 50 • <i>Time Schedule Modules</i> 51 • <i>Optimal Start/Stop Modules</i> 52 • <i>Optimal Start Adaptive Process</i> 53 	
	Page

• <i>Optimal Stop Operation</i>	54
• <i>Programmable Function Modules: Control Algorithms</i>	55
• <i>Numeric Calculation Algorithms</i>	72
• <i>Numeric Calculation Algorithms for Version 1.1 or Later</i>	76
• <i>Other Functions</i>	77
• <i>Programmable Logic Control</i>	82
• <i>Dial-up Feature</i>	89
• <i>Power Up Conditions</i>	90
• <i>Password Feature (Versions 1.4, 2.4, 3.4, or Later)</i>	90
• <i>Trend Log Feature (Versions 1.4, 2.4, 3.4, or Later)</i>	91

Display Panel and Keypads **93**

• <i>Front Panel Layout</i>	93
• <i>Startup Mode</i>	99
• <i>Download Mode (Version 1.1 or Later)</i>	99
• <i>Time Schedule Mode</i>	99
• <i>Time Schedule Event Programming</i>	101
• <i>Realtime Clock Calendar</i>	102
• <i>Analog Input Display Mode</i>	106
• <i>Analog Input Scroll Mode</i>	107
• <i>Digital Input Display Mode</i>	107
• <i>Output Module Display Mode</i>	108
• <i>Digital Counter Display Mode</i>	110
• <i>Programmable Function Module Display Mode</i>	111
• <i>Analog/Digital Constant Display Mode</i>	115

Specifications and Technical Data **117**

• <i>Products Available in North America</i>	120
• <i>Products Available in Europe</i>	122

Appendix A: LONWORKS N2E Bus Poll Estimation Worksheet **125**

DX-9100 Extended Digital Plant Controller (Including DX-912x LONWORKS®, Version 3)

Introduction

In this document, Facility Management System (FMS) is a generic term, which refers to the Metasys® Network, Companion™, and Facilitator™ supervisory systems. The specific system names are used when referring to system-specific applications.

This document covers all three versions of the DX-9100 Extended Digital Controller, including the DX-912x LONWORKS® version.

The DX-9100 is the ideal digital control solution for multiple chiller or boiler plant control applications, for the Heating, Ventilating, and Air Conditioning (HVAC) process of Air Handling Units (AHUs) or for distributed lighting and related electrical equipment control applications. It provides precise Direct Digital Control as well as programmed logic control.

In a standalone configuration, the DX-9100 controller has both the hardware and software flexibility to adapt to the variety of control processes found in its targeted applications. Along with its outstanding control flexibility, the controller can expand its input and output point capability by communicating with I/O Extension Modules on an extension bus, and provides monitoring and control for all connected points via its built-in Light-Emitting Diode (LED) display. Versions 1 and 2 can communicate on the Metasys N2 Bus, providing point control to the full FMS. The Version 3 controller uses the LONWORKS (Echelon®) N2E Bus of the Metasys Control Module (NCM311 or NCM361 in Europe, NCM300 or NCM350 elsewhere) in place of the N2 Bus.

The DX-9100 has two packaging styles. In *Version 1*, all terminals for field wiring are located within the controller enclosure. *Versions 2 and 3* require a separate field wiring mounting base or cabinet door mounting frame, which enables all field wiring to be completed before the controller is installed.



Figure 1: Version 1 (DX-9100-8154)

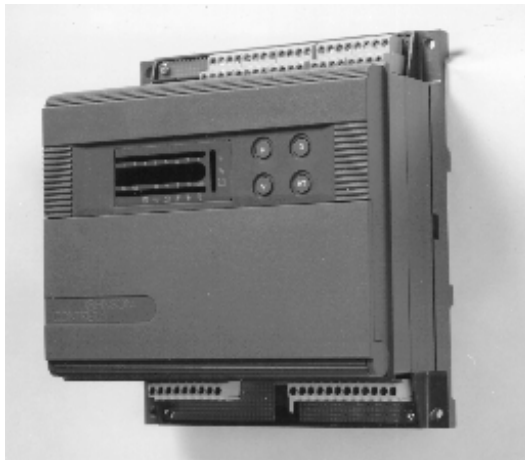

**Figure 2: DX-9100-8454 or FA-DX9100-8454 (Version 2)/
DX-912x-8454 (Version 3) with Mounting Base**

The DX-9100 processes the analog and digital input signals it receives, using 12 multi-purpose programmable function modules, a software-implemented Programmable Logic Controller (PLC), time schedule modules, and optimal start/stop modules to produce the required outputs (depending on the module configuration), operating parameters, and programmed logic.

All versions of the DX-9100 controller are configured by using a Personal Computer (PC) with GX-9100 Graphic Configuration Tool software supplied by Johnson Controls. Changes to the configuration can also be made by using an SX-9120 Service Module.

**Versions 1 and 2
(N2 Bus)**

The DX-9100 can accept eight analog inputs and eight digital inputs.

Version 1 of the controller (DX-9100-8154) provides up to eight output modules, which are configured to give two analog outputs and six digital outputs (triacs). The triacs can be separately configured to provide six on/off or pulse outputs, three duration adjust outputs, three position adjust (incremental) outputs, three start/stop outputs, or any combination using up to six triacs.

Version 2 of the controller (DX-9100-8454 or FA-DX9100-8454) provides six additional analog output modules, giving a total of eight analog outputs.

The DX-9100 unit (Versions 1 and 2) has two communication links. One is called the N2 Bus or Bus 91 (the term “Bus 91” is not used in North America) and is used to interface to a supervisory unit. The other link is called the XT Bus and is used to expand the DX-9100 input/output capability by interfacing up to eight XT-9100 or XTM-905 extension modules. The DX-9100 input/output can be extended by up to 64 remote input/outputs, analog or digital, depending on the type of the connected extension modules and XP expansion modules. Point connections are made on XP modules, which are monitored and controlled by the XT-9100 or XTM-905 modules. Refer to the *XT-9100 Technical Bulletin (LIT-6364040)* and the *XTM-905 Extension Module, XPx-xxx Expansion Modules Technical Bulletin (LIT-6364210)*. One XP module can provide either eight analog points or eight digital points. Two XP modules connected to one extension module can provide eight analog and eight digital points, or sixteen digital points.

Version 1 or 2 of the DX-9100 can be used as a standalone controller or it can be connected to an FMS through the RS-485 serial communications bus (N2 Bus or Bus 91).

**Version 3
(LONWORKS-
Compatible
N2E Bus)**

Version 3 of the controller (DX-912x-8454) brings peer-to-peer communication to the already rich feature set of the Version 2 controller, and enhanced alarm reporting capability when used as an integral part of an FMS.

The new communications features are provided by the LONWORKS network, which enables Version 3 controllers to pass data between each other and to send event-initiated data to the NCM300 or NCM350 (NCM311 or NCM361 in Europe) Network Control Module (NCM) in the FMS. The LONWORKS (Echelon) N2E Bus is used in place of the N2 Bus, and the NCM300 or NCM350 (NCM311 or NCM361 in Europe) must be fitted with a LONWORKS driver card.

The Version 3 controller retains all the input/output point and control capabilities of the Version 2 controller, including the point expansion feature using extension modules and expansion modules.

In addition to the Version 2 features, the Version 3 controller has network input and output points, which can be configured to transmit and receive data over the LONWORKS Bus. Each controller may have up to 16 network analog input modules, 16 network analog output modules, 8 network digital input modules, and 8 network digital output modules. While network analog input and output modules each contain a single analog value, the network digital input and output modules each contain 16 digital states, which are transmitted as a block between controllers. The transmission of point data is managed by the LONWORKS network and is independent of the supervisory functions of the FMS Network Control Module. A network of Version 3 controllers can be installed to share analog and digital data between controllers on a peer-to-peer basis; a Network Control Module is not required unless the network is to be supervised by an FMS.

Complex control strategies may now be performed in multiple DX-912x controllers without the need for network data exchange routines in a supervisory controller. Applications include the control of multiple, interrelated air handling units, and large hot water or chilled water generating plants with components distributed in various locations within the building.

Where should the DX-912x be used?

The DX-912x is the newest member of the very successful family of DX controllers and uses the 78K baud peer-to-peer LONWORKS communication bus. To support many additional Metasys N2 device features, the DX-912x is also designed to respond to polled N2 messages. The result is that the DX-912x performs exceptionally well in certain applications, and slower than standard DX-9100s in others. In particular, the user may notice this slower performance when trying to display system summaries and graphics on an FMS Operator Workstation (OWS).

Use the DX912x in:

- *Small buildings controlled by two or three DX controllers, without an FMS.* Small, standalone systems are the best applications for the DX-912x. For control operations, the DX-912x can share data on a peer-to-peer basis. By adding the DX LCD Display Terminal (DT-9100), you can provide a local user interface that can be configured to give the users the specific data they need to see.

- *Networked systems with peer-to-peer communications required by the specification that share data between controllers. In this case, you must make sure that the DX-912x meets the performance requirements. See a list of the most important points to consider below.*
- *Networked systems where the majority of data traffic is in peer-to-peer communication between DX-912x controllers and the number of points on the OWS screen is limited to below 30 points.*

Do not use the DX-912x in:

- Systems that require a large number of DXs (typically more than five per N2E trunk) and are likely to have frequent change-of-state reports (sent at a rate of more than one per second for an extended time) See *Appendix A: LONWORKS N2E Bus Poll Estimation Worksheet* at the end of this document to calculate the maximum number of DX controllers to use in a particular system.
- Systems that require the gathering of trend or point history data from a large number of points in the DX-912x controllers or from a few points at a very fast rate.
- Systems that require many or frequently running Graphic Programming Language (GPL) processes in the NCM, which need to poll the controllers for data.
- It is not recommended to add DX-912xs to NCMs that already have N2 devices connected.
- Process automation and pharmaceutical applications that use NCMs are generally not good candidates for using the DX-912x because of the requirement for a high volume of communication traffic between the controllers and the NCM for data gathering and global process interaction.

**LONMARK®
Compatibility**

The Version 3 controller has been approved as a LONMARK device and conforms to the LONMARK specification for network data transmission.



Figure 3: LONMARK Logo

Related Information

Refer to Table 1 for additional information on DX controllers:

Table 1: Related Literature

Document Title	Code Number	FAN
<i>DX-9100 Configuration Guide</i>	<i>LIT-6364030</i>	636.4 1628.4
<i>GX-9100 Software Configuration Tool for Windows User's Guide</i>	<i>LIT-6364060</i>	636.4 1628.4
<i>LONWORKS N2E Bus Technical Bulletin</i>	<i>LIT-6364100</i>	636.4
<i>DX LCD Display User's Guide</i>	<i>LIT-6364120</i>	636.4 1628.4

About This Manual

This manual contains details of the hardware configuration of the DX-9100 series of controllers. This includes information on mounting, installation, and startup.

This manual also gives an overview of the internal operation and the software functional modules. Refer to the *DX-9100 Configuration Guide (LIT-6364030)* for detailed programming information on these modules.

A guide to the operation of the front panel and keyboard is included at the end of this manual.

Features

The following lists some of the DX-9100 Extended Digital Controller features:

- fully configurable, using GX-9100 Graphic Configuration software
- communications bus (RS-485 port for N2 Bus) for FMS (*DX-9100, Versions 1.x and 2.x*)
- LONWORKS TP78 transceiver for network communications (*DX-9120, Versions 3.0, 3.1, 3.2 and 3.4*)
- LONWORKS FTT10a transceiver for network communications. (*DX-9121, Version 3.4*)
- automatic reporting of alarms and changes-of-logic states on LONWORKS network (*Version 3*)
- socket for service module (SX-9120) connection
- RS-232-C port for loading controller configurations and for connection of the DT-9100 DX LCD Display (*Versions 2 and 3*)
- eight high resolution (13-bit) analog inputs
- eight digital inputs from potential-free contacts, each with transition counter
- two isolated analog outputs (*Version 1 only*)
- eight isolated analog outputs (*Versions 2 and 3 only*)

- six isolated digital outputs
- twelve programmable function modules, selected from a library of functions, including:
 - P, PI, PID or on/off control, dual PID, dual on/off control
 - numeric calculation modules for programmed mathematical function
 - sequencer modules
 - totalization modules for analog or digital inputs
- programmable logic control module with a set of logic functions including:
 - AND, ANDNOT, OR, ORNOT, COS (Change-of-State), OUT, OUTNOT, SET, RESET, AND LOGIC BLOCK, and OR LOGIC BLOCK
- eight time schedule modules
- two optimal start/stop modules
- eight extension/expansion I/O module sets, each supporting up to eight inputs/outputs
- sensor readings updated every second (including inputs from up to eight extension modules with analog inputs/outputs)
- inputs and outputs via the LONWORKS network (*Version 3*). There are 16 network analog inputs, 16 network analog outputs, 8 network digital input blocks of 16 inputs, and 8 network digital output blocks of 16 outputs
- built-in isolating transformer
- integral display panel with keypads
- enclosure material of self-extinguishing ABS/polycarbonate
- surface or DIN rail mounting
- field wiring mounting base (*Versions 2 and 3*)
- cabinet door mounting frame (*Versions 2 and 3*)

Installation

**Version 1
(DX-9100-8154)**

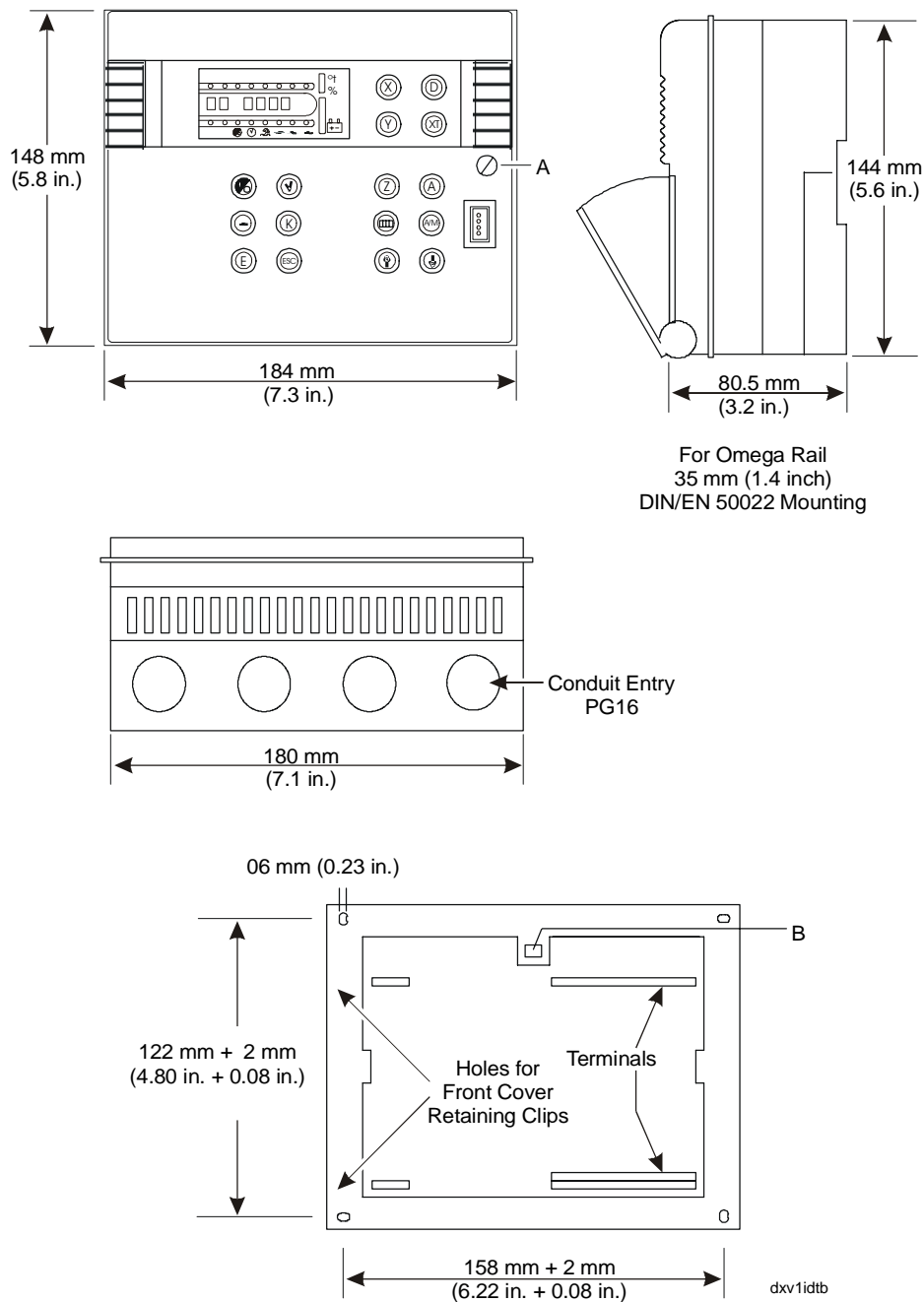

Figure 4: Installation Details of Version 1

Note: The Version 1 controller (DX-9100-8154) is not available in North America.

Mounting Instructions

Mount the DX-9100-8154 (Version 1) as follows:

1. Remove front cover by releasing Screw A (Figure 4), lifting the cover, and detaching it from the base. The cover may be hooked onto the base in the open position by engaging the two lugs on the left of the controller cover into the corresponding holes in the base. Alternatively, it may be completely removed by detaching the ribbon cable from the PC board in the cover.
2. For surface mounting, use four (4.2 mm diameter) screws. (Four 25 mm long screws are supplied with the controller.)
3. For DIN rail mounting, snap the controller onto the 35 mm (1 3/8 inch) rail. To release the controller, insert a screwdriver in Slot B (Figure 4) and lift the retaining clip.
4. The retaining clip is spring-loaded, you can also remove the controller without a screwdriver by carefully pushing the controller up against the clip and then tilting the top forward to release the top lug from the DIN rail.
5. To connect the wiring:

Terminations are made via the terminal blocks on the lower circuit board, which accept 1 x 1.5 mm² (16 AWG) cable. See Figure 5 for connection details.

Terminations of the communications bus cable and extension bus cable are made via the connectors provided with the controller.



CAUTION: The CMOS circuits in the controller are sensitive to static electricity. Take suitable precautions.

Note: The connection, wiring, and jumper information that follows is valid only for Version 1 controllers.

**Connection
Details
(Version 1 Only)**

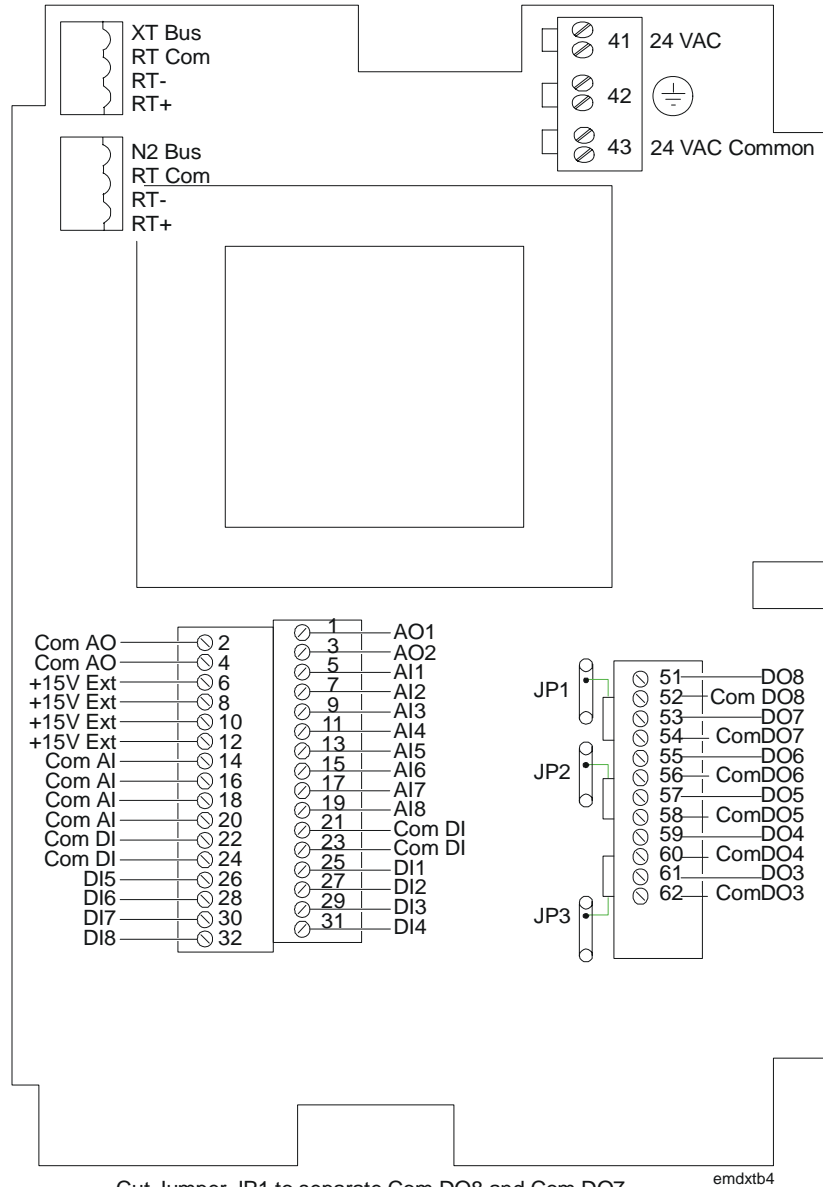

Cut Jumper JP1 to separate Com DO8 and Com DO7.
 Cut Jumper JP2 to separate Com DO5 and Com DO6.
 Cut Jumper JP3 to separate Com DO3 and Com D04.

Figure 5: Connection Details for Version 1

Note: The following commons are electrically independent:

- Analog Input Common (for AI1 to 8)
- Analog Output Common (for AO1 and 2)
- 24V Common/Digital Input Common (for DI1 to 8)*
- Digital Output 3 and 4 Common (can be separated by cutting JP3)
- Digital Output 5 and 6 Common (can be separated by cutting JP2)
- Digital Output 7 and 8 Common (can be separated by cutting JP1)
- N2 Bus/XT Bus Common (Reference)

*24V Common and Digital Input Common are electrically connected.

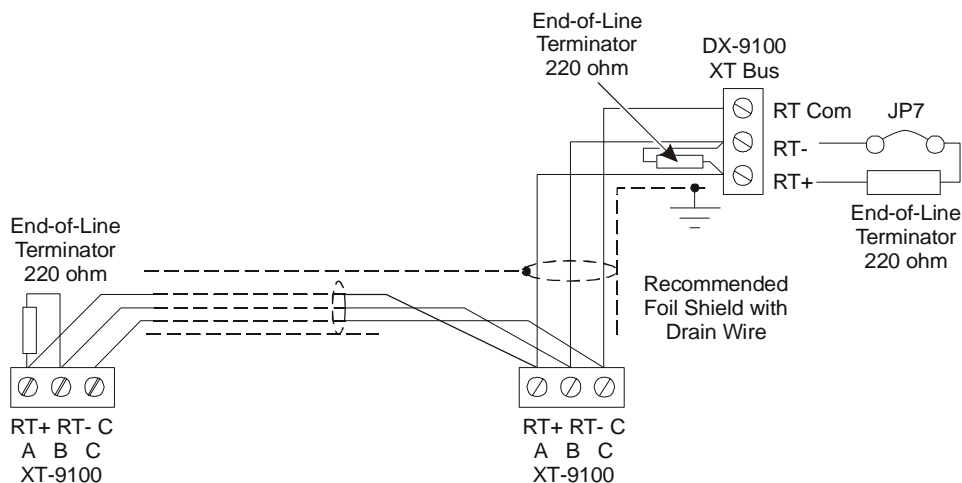

emdxtb5n

Figure 6: Connection Details for the XT Bus (Version 1)

Maximum: Eight XT-9100s or XTM-905s

Maximum bus length: 1,200 meters (4,000 ft)

Version 1 Only—Install 220 ohm end-of-line resistors at each end of the XT Bus line when the bus length is greater than 100 meters (330 feet). When the DX-9100 is at one end of the bus, the end-of-line resistor may be connected by inserting JP7 inside the controller. (See the *Jumper Details* section further in this document.) When the bus length is less than 100 meters (330 feet), install one 220 ohm end-of-line resistor at the DX-9100 only, or insert JP7 inside the controller.

**Connection
Details for
Download/Upload**

For download and upload via the N2 Bus as shown below, the Version 1 DX-9100 controller is connected to a PC containing GX-9100 software.

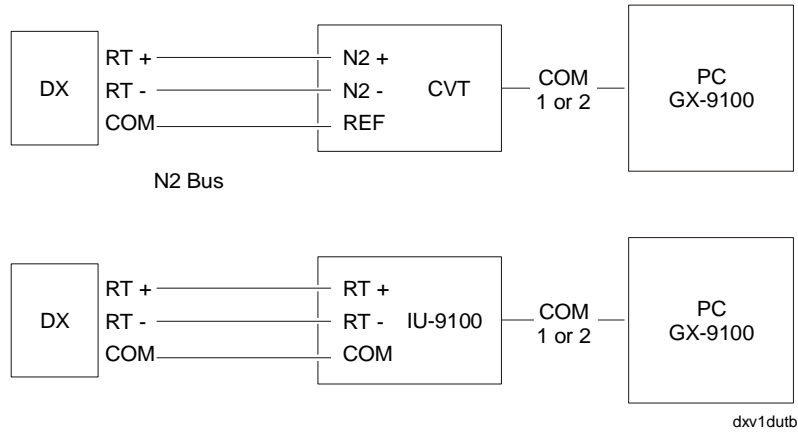

Figure 7: Connection Details for Download/Upload of Version 1 Controller

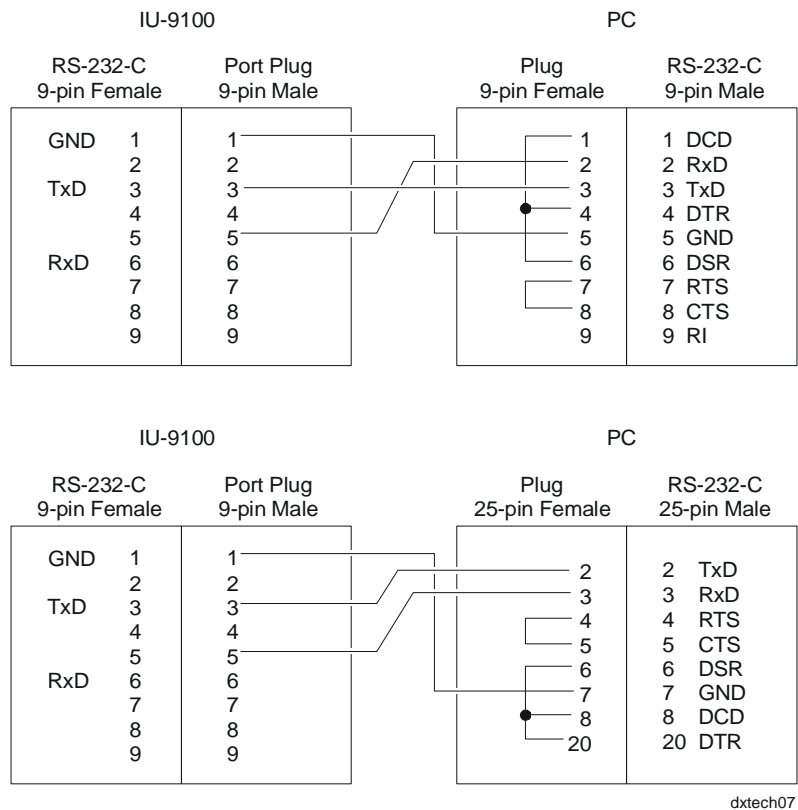

Figure 8: PC to IU-9100 Cabling Details, Version 1

Jumper Details

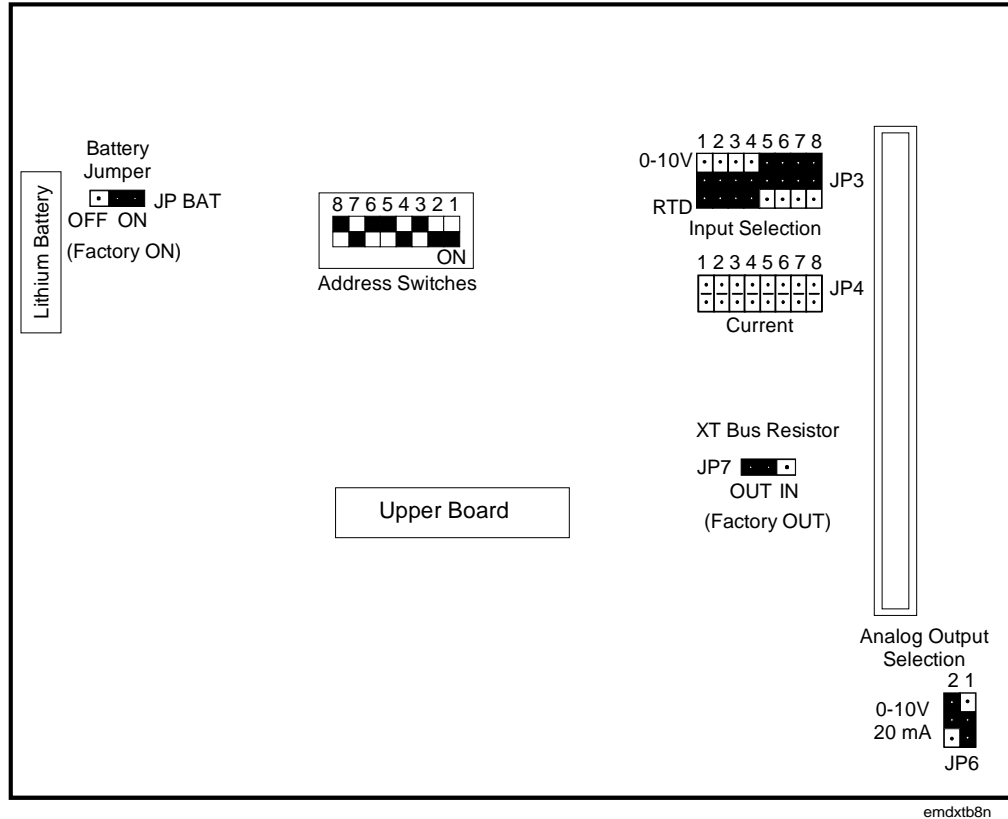



Figure 9: Jumper Details for Version 1

 **CAUTION:** Do not change the jumper position of JP2, as it is for internal use only and is preset at the factory.

The following are general guidelines for setting jumpers on Version 1 controllers:

1. All jumper selections must be made **before** power is applied to the controller.
2. Select **analog input type** using one jumper per input in the respective position for the input number in JP3 or JP4.

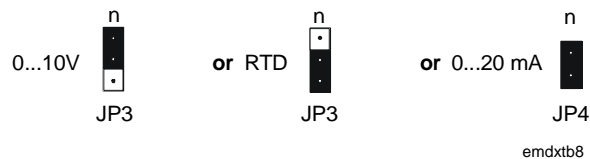

Figure 10: Jumper Positions for Analog Inputs

3. A maximum of four 0-20 mA transmitters can be powered by the controller. (Maximum current from 15V supply is 100 mA.)

4. Use jumpers JP6 to select **Analog Output Type**.

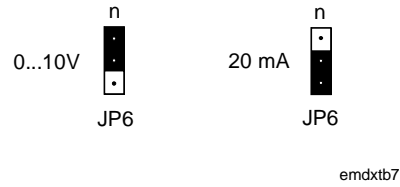

Figure 11: Jumper Positions for Analog Outputs

5. Select the **Controller Address** (for the FMS) on the address switches in 8-bit binary format.

Switch Number	8	7	6	5	4	3	2	1
Decimal Equivalent	128	64	32	16	8	4	2	1

Example for switch settings:

8	7	6	5	4	3	2	1	
Off	On	Off	Off	On	Off	On	On	Address 75
-	64	-	-	8	-	2	1	

$$(64 + 8 + 2 + 1 = 75)$$

6. Jumper JP BAT is set to On at the factory and should only be set to Off if the controller is to be kept in storage without power for an extended period of time. The jumper must be set to On before the controller is installed and powered up.
7. Jumper JP7 allows the termination of the XT Bus with a 220 ohm resistor within the controller such that no external resistor on the XT Bus terminal block is required.

Typical Wiring

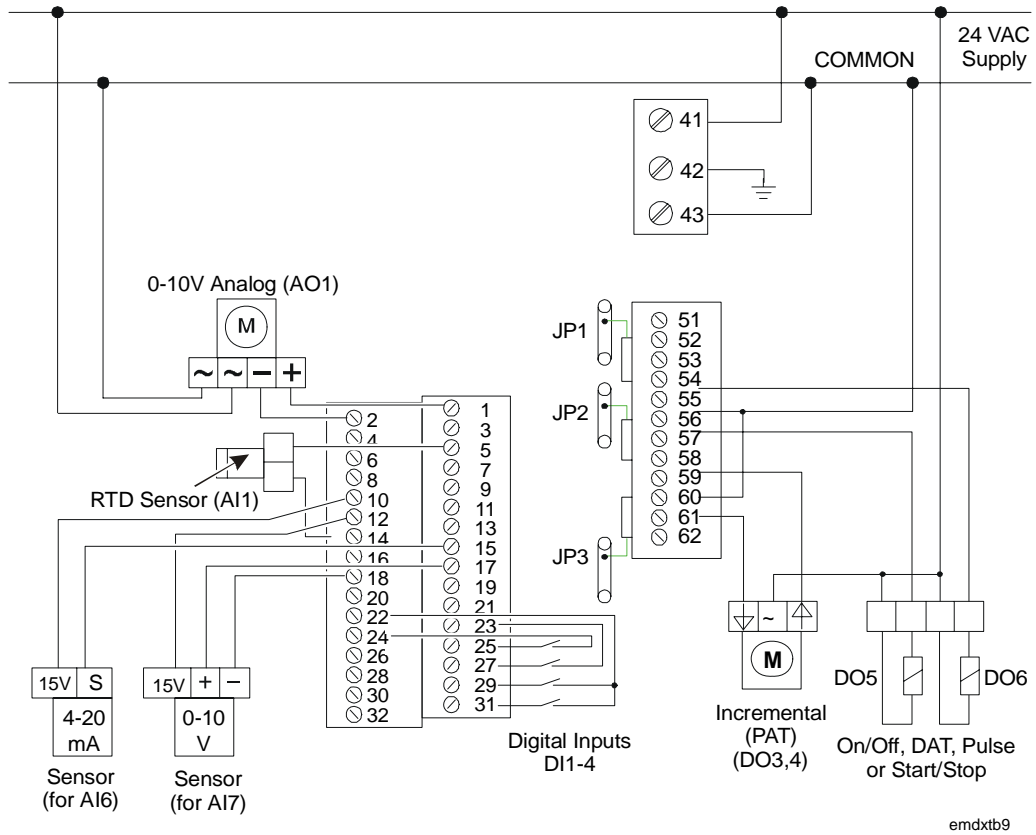

Figure 12: Typical Wiring Diagram of Version 1

Note: The diagram shows the wiring using a common transformer for controller supply, and input and output devices. If required, separate transformers can be used.

Version 2
(DX-9100-8454
or
FA-DX9100-8454)
and Version 3
(DX-912x-8454)

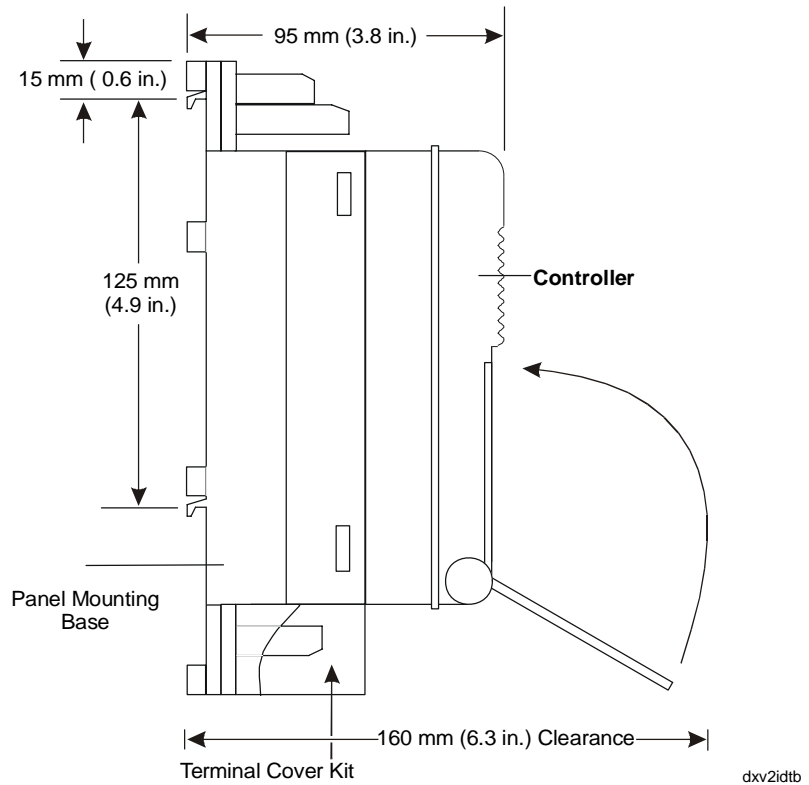
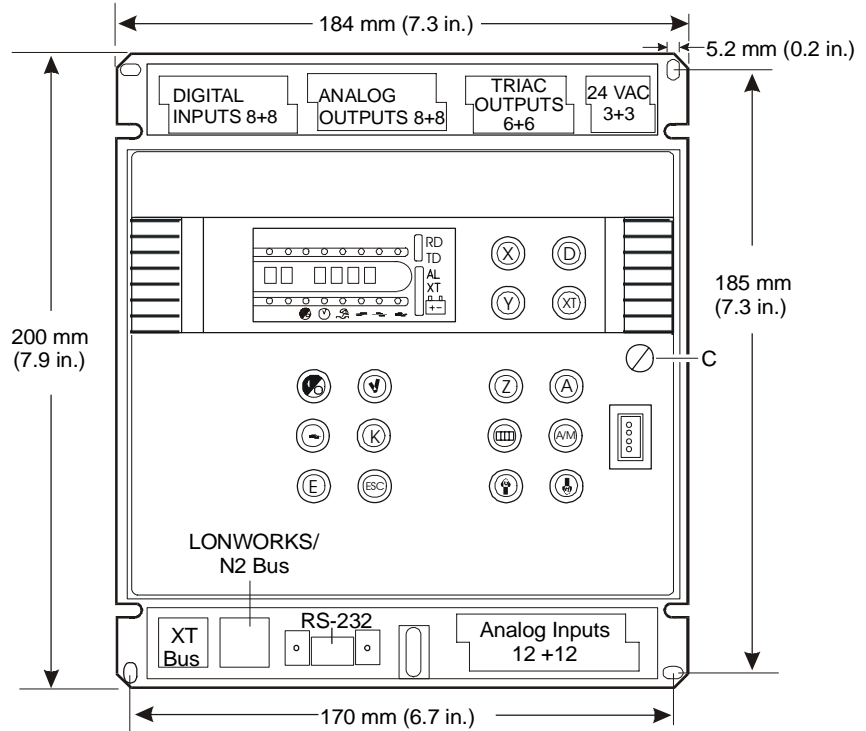

Figure 13: Installation Details of Versions 2 and 3 with Panel Mounting Base

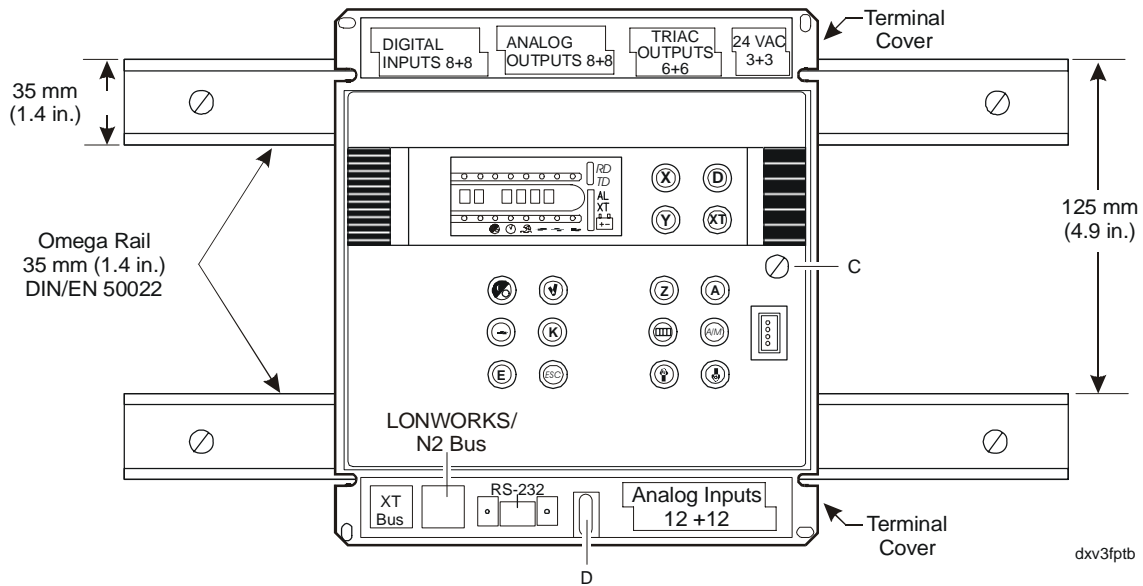

Figure 14: Version 2 or 3 with Panel Mounting Base on DIN Rails

Mounting Instructions

DX Controller with Panel Mounting Base

To mount the Version 2 or 3 DX controller with panel mounting base:

1. Remove the snap-on, transparent, plastic terminal covers if installed, from the top and bottom of the base. Place in a safe location.
2. If the controller has already been attached to the base, proceed as follows to detach it:

Open the front panel flap. Release Screw C. Pull the right side of the controller away from the base until it is free. Then completely remove the controller from the base, detaching the lugs on the left side. Place the controller in a safe location.

3. *For surface mounting:*

Use four screws (4.2 mm diameter) to fix the controller to the surface. (Four 25 mm long screws are supplied with the base.)

For DIN rail mounting:

Install two DIN rails as shown in Figure 14.

Loosen Screw D in the oval slot and pull the metal plate downwards as far as it will go. Place the base over the DIN rails so that the channels on the back of the base cover the DIN rails, and pull the base downward to engage it in position.

Lock the base in position by sliding the metal plate upwards until it covers the lip of the lower DIN rail, and tighten Screw D. Check to be sure the base is tightly attached to the rails.

4. Wiring terminations are made via the terminal blocks, which accept 1 x 1.5 mm² (16 AWG) cable, on the top and bottom part of the base. See Figure 16. Terminations of the LONWORKS, N2 or XT communications bus cables are made via the connectors provided with the base.

5. Replace or install the terminal covers.

Note: This is mandatory in Europe for CE Directive compliance when the base is not mounted inside a metal cabinet; optional elsewhere.

The side wall of the terminal cover is designed such that part of it can be removed to allow more space for the wiring to the upper row of terminals. Remove sections of the side wall as necessary.

6. Verify that the wiring to the base has been correctly installed, and that voltage levels are appropriate for the various input signals according to the application.
7. Set the jumpers and address switches at the back of the controller as required. See *Jumper Details*, Figure 22.
8. Attach the controller to the base, by first fitting the lugs on the left side of the controller into the base, and then by pressing the controller firmly against the base on the right side. Open the front panel flap and secure the controller to the base by tightening Screw C.

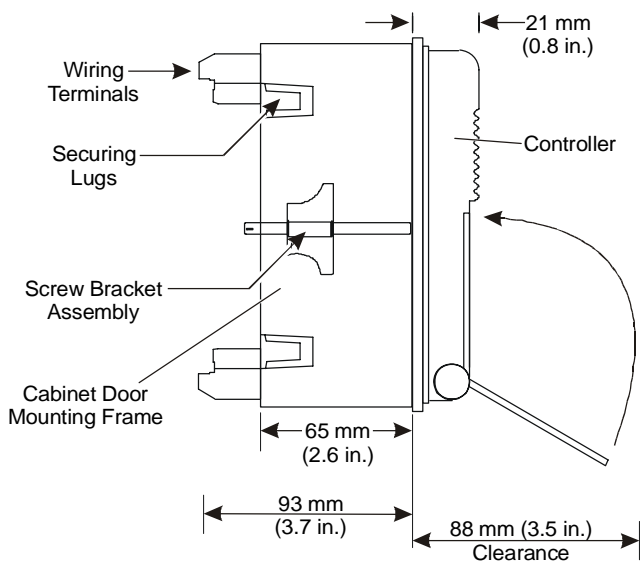
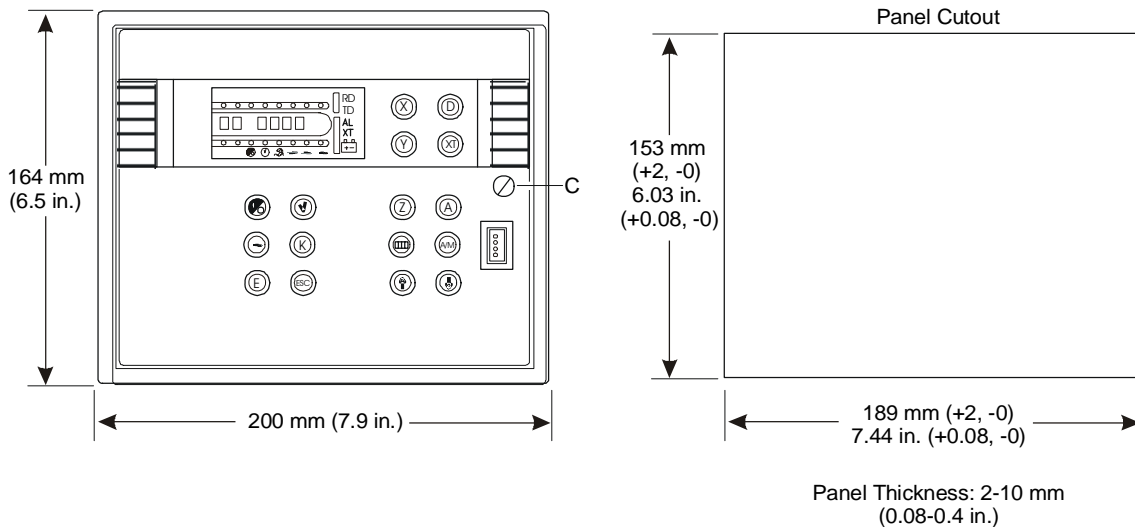

dx23idtb

Figure 15: Installation Details of Versions 2 and 3 with Cabinet Door Mounting Frame

DX Controller, Cabinet Door Mounting Frame

To mount the Version 2 or 3 DX controller DX-9100-8996 cabinet door mounting frame:

1. If the controller has already been installed in the frame, proceed as follows to remove it:

Open the front panel flap. Release Screw C. Slide the controller out of the frame until it is free. Place the controller in a safe location.
2. Make a panel cutout in the cabinet door as shown in Figure 15. Note that the frame may be mounted in a panel with a thickness of 2-10 mm.

Slide the frame into the cutout and secure using the two screw bracket assemblies provided.
3. Wiring terminations are made via the terminal blocks, which accept $1 \times 1.5 \text{ mm}^2$ (16 AWG) cable at the back of the frame. See Figure 17. Terminations of the LONWORKS N2 and XT communications bus cables are made via the connectors provided with the base.
4. Verify that the wiring to the frame has been correctly installed, and that voltage levels are appropriate for the various input signals according to the application.
5. Set the jumpers and address switches at the back of the controller as required. See *Jumper Details*, Figure 22.
6. Slide the controller into the frame until the lugs on the left hand side of the frame engage the controller. Open the front panel flap and secure the controller to the frame by tightening Screw C (see Figure 15).

Notes: The Version 2 DX-9100-8454 or FA-DX9100-8454 controller must be connected to an RS-485/N2 Bus.

The Version 3 DX-9120-8454 controller with the TP78 transceiver must be connected to a LONWORKS N2E Bus where all the controllers on the bus are fitted with a TP78 transceiver and the NU-NET201-0 LONWORKS network card is installed in the NCM.

The Version 3 DX-9121-8454 controller with the FTT10a transceiver must be connected to a LONWORKS N2E Bus where all the controllers on the bus are fitted with a FTT10 or FTT10a transceiver and the NU-NET202-0 LONWORKS network card is installed in the NCM.

The Version 3 controller with the FTT10a transceiver requires a different mounting base or frame from the controller with the TP78 transceiver. See Table 2.

Table 2: Order Codes for Controller Mounting Bases and Frames

Controller	Panel Mounting Base	Cabinet Door Mounting Frame
DX-9100-8454 Version 2	North America: DX-9100-8990 DX-9100-8990 Europe: DX-9100-8997	DX-9100-8996
DX-9120-8454 Version 3 (TP78)	North America: DX-9100-8990 Europe: DX-9100-8997	DX-9100-8996
DX-9121-8454 Version 3 (FTT10)	DX-9121-8997	DX-9121-8996

See Tables 7 through 11 for the full range of DX-related items and accessories and their ordering codes.

Connection Details

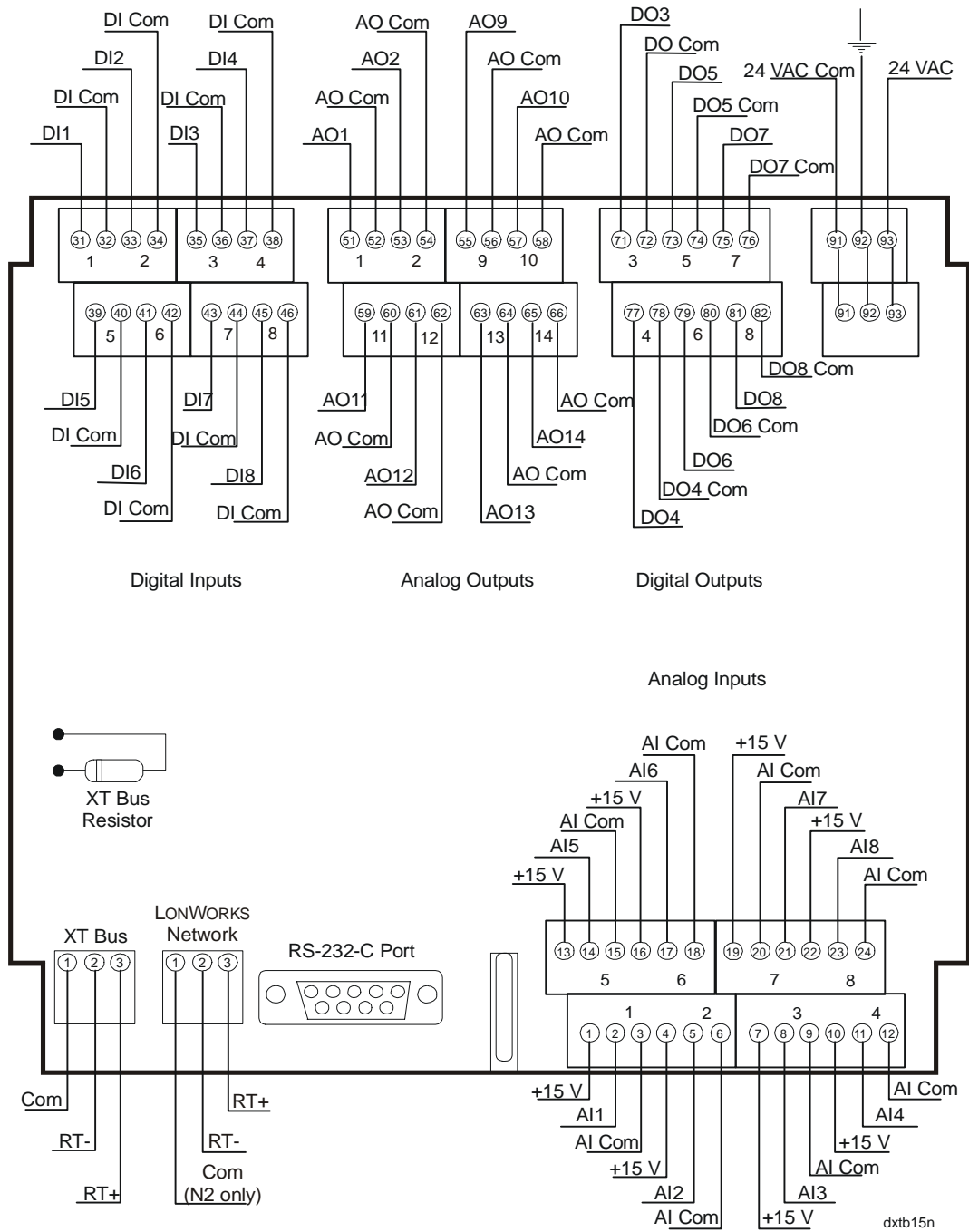

Figure 16: Connections at the Top and Bottom of the Panel Mounting Base

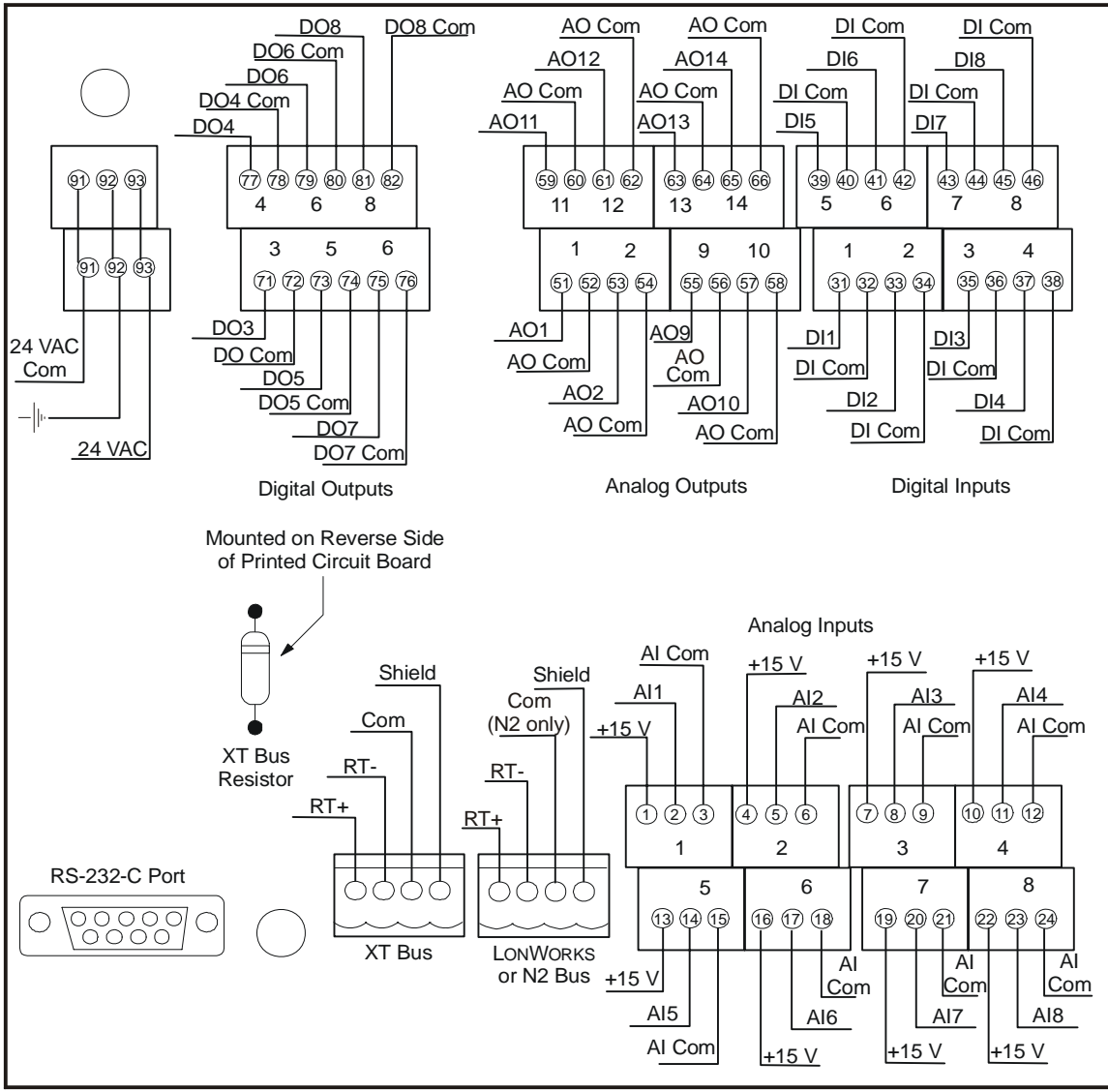

Figure 17: Connections at the Top and Bottom of the Cabinet Door Mounting Frame

Notes: The connection, wiring, and jumper information that follows is valid for Version 2 and 3 controllers with either type of mounting: panel mounting base or cabinet door mounting frame.

The following commons are electrically independent:

- Analog Input Common (for AI1 to AI8)
- Analog Output Common (for AO1, AO2, AO9 to AO14)
- 24 VAC Common/Digital Input Common (for DI1 to DI8)*
- Digital Output 3 Common
- Digital Output 4 Common
- Digital Output 5 Common
- Digital Output 6 Common
- Digital Output 7 Common
- N2 Bus/XT Bus Common (Reference)

*24V Common and Digital Input Common are electrically connected.

If required by local electrical codes, the 24 VAC Common/Digital Input Common may be connected to a clean earth/ground termination. The Analog Common may be connected to the 24 VAC Common at the controller for activating devices with a single common terminal for 24 VAC Common and Analog Signal Common. Under no circumstances should the 24 VAC or any of the Analog Outputs (AO1 through AO14) be connected to an earth/ground termination.

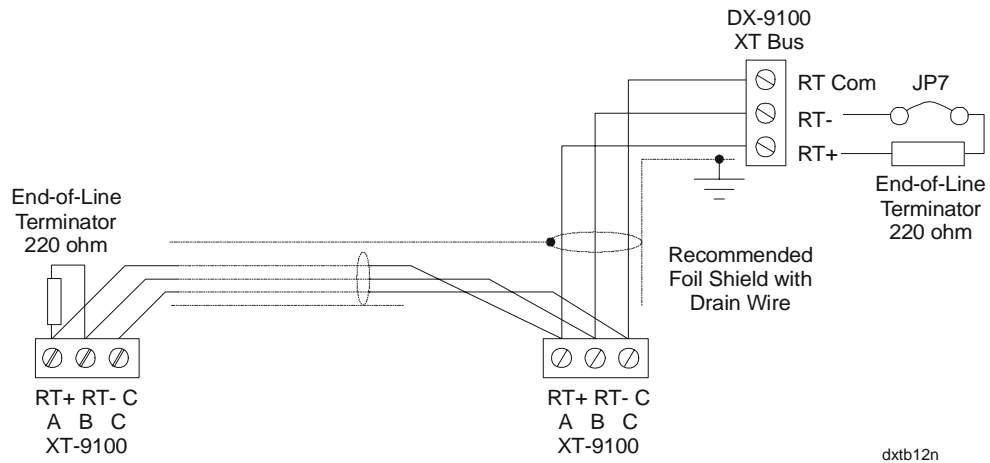

Figure 18: Connection Details for the XT-Bus for Connection to Version 2 or 3 DX

Maximum: Eight XT-9100s or XTM-905s

Maximum bus length: 1,200 meters (4,000 feet)

Install 220 ohm end-of-line resistors at each end of the XT Bus line when the bus length is greater than 100 meters (330 feet). When the DX-9100 is at one end of the bus, the end-of-line resistor is already installed in the mounting base or frame. When the DX-9100 is not at one end of the bus, install two resistors externally, and use side-cutters to remove the XT Bus resistor on the mounting base or frame. (See Figures 16 and 17.) When the bus length is less than 100 meters (330 feet), no external resistors are required, but the end-of-line resistor in the mounting frame must *not* be removed.

Connection Details for Download/ Upload

The connection between the PC and the Version 2 DX-9100 controller is made via an IU-9100 or MM-CVT-101 converter unit, which in turn must be connected to drive the N2 Bus (Bus 91) on which the DX-9100 controller resides. With this connection configuration, each DX-9100, with its connected extension modules, and any XT-9100 or XTM-905 modules on the bus can be downloaded, one after the other, by entering the appropriate address in the GX-9100 Configuration Tool. The DX controller must be disconnected from the supervisory system to use this method.

The DX-9100 Version 2 or 3 controller, with its connected extension modules, may be downloaded directly via its RS-232 port. With this connection configuration, only this one DX-9100 and its extension modules can be downloaded.

Note: The Version 3 controller may be connected to a PC only via its RS-232-C port.

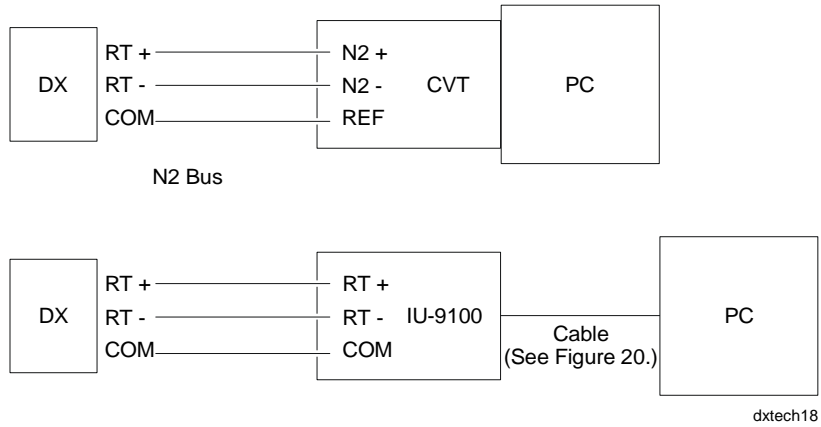

Figure 19: Connection Details for Download/Upload of DX-9100, Version 2

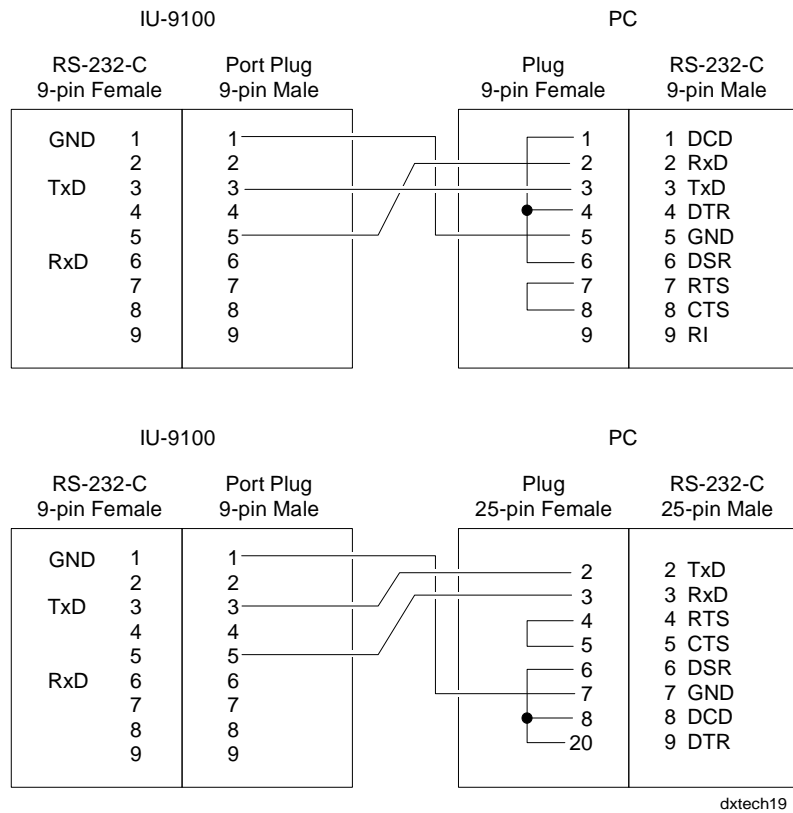

Figure 20: IU-9100 to PC Connection Details, Version 2

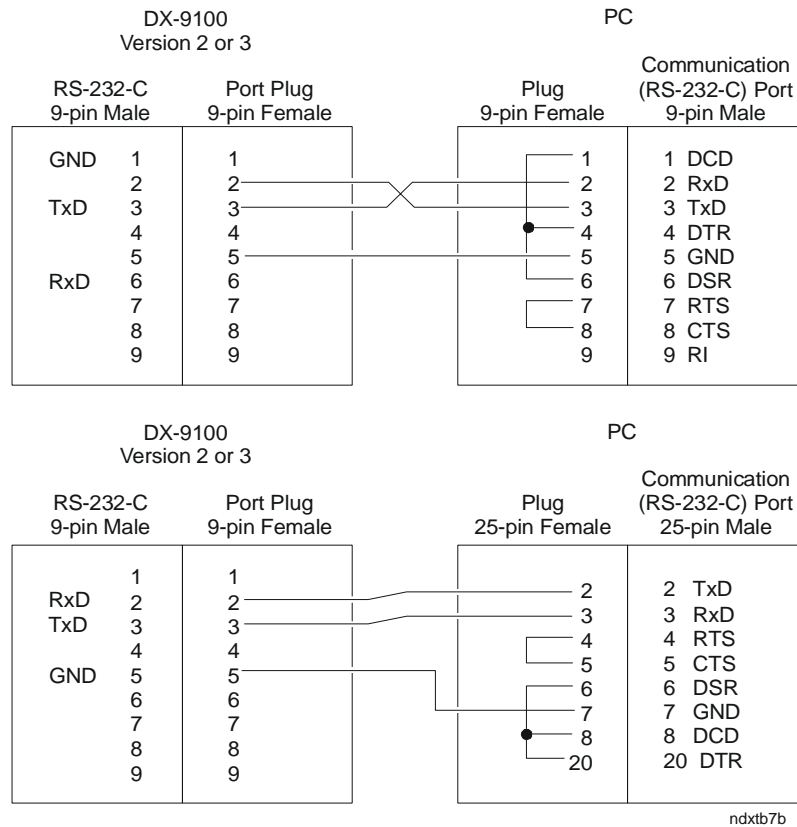

Figure 21: Direct Download, Version 2 or 3 Controller

Note: This is a null modem cable available at most electronic stores. However, make sure it has the above configuration, as there is no universal null modem cable standard. You can also use a straight through cable with a null modem adapter.

Jumper Details

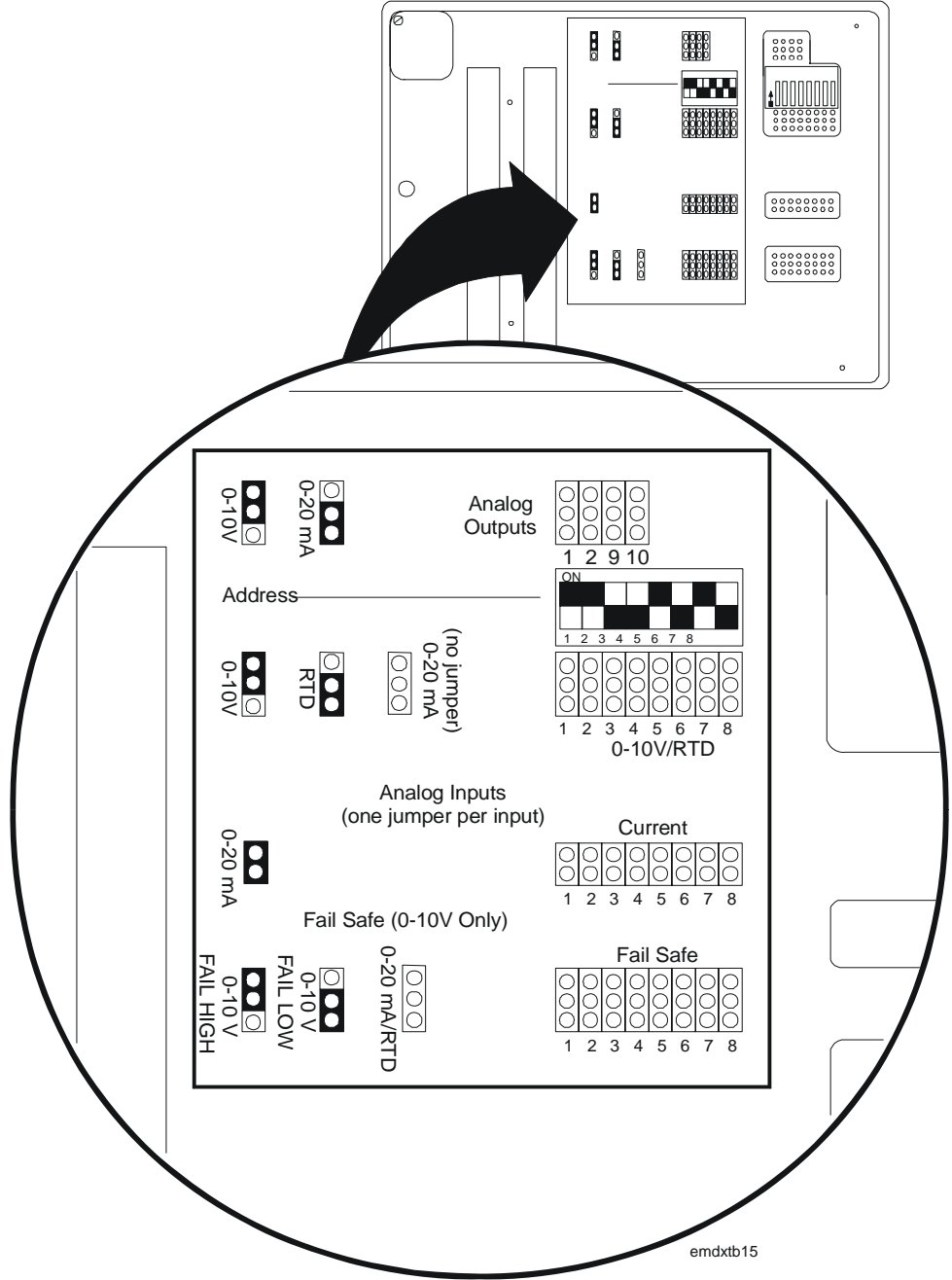

Figure 22: Jumper Details for Versions 2 and 3

The following are guidelines for setting jumpers on Version 2 or 3 controllers:

1. Make all jumper selections **before** fixing the controller to the base.
2. Select the analog input type using one jumper per input in the 0-10V/RTD jumper field or Current jumper field.

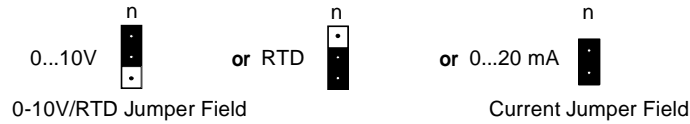

Figure 23: Jumper Positions

For 0-10V inputs only, install a jumper in the fail high or fail low position if fail safe operation is required. Fail high means that the controller assumes a 10V input when there is no input signal, and fail low means that the controller assumes a 0V input when there is no input signal (open circuit). If the input signal fails, this gives the programmer the ability to fail the signal so that the controller assumes a Fail Safe mode.

3. Select the analog output type using one jumper per output. Note that analog outputs AO11 to AO14 are 0-10V only and require no jumper setting.
4. Select the controller address (for FMS) on the address switches in 8-bit binary format.

Switch Number	1	2	3	4	5	6	7	8
Decimal Equivalent	1	2	4	8	16	32	64	128

Example for switch settings:

1	2	3	4	5	6	7	8	
Off	Off	On	On	Off	On	Off	On	Address 172
-	-	4	8	-	32	-	128	

$$(4 + 8 + 32 + 128 = 172)$$

Typical Wiring

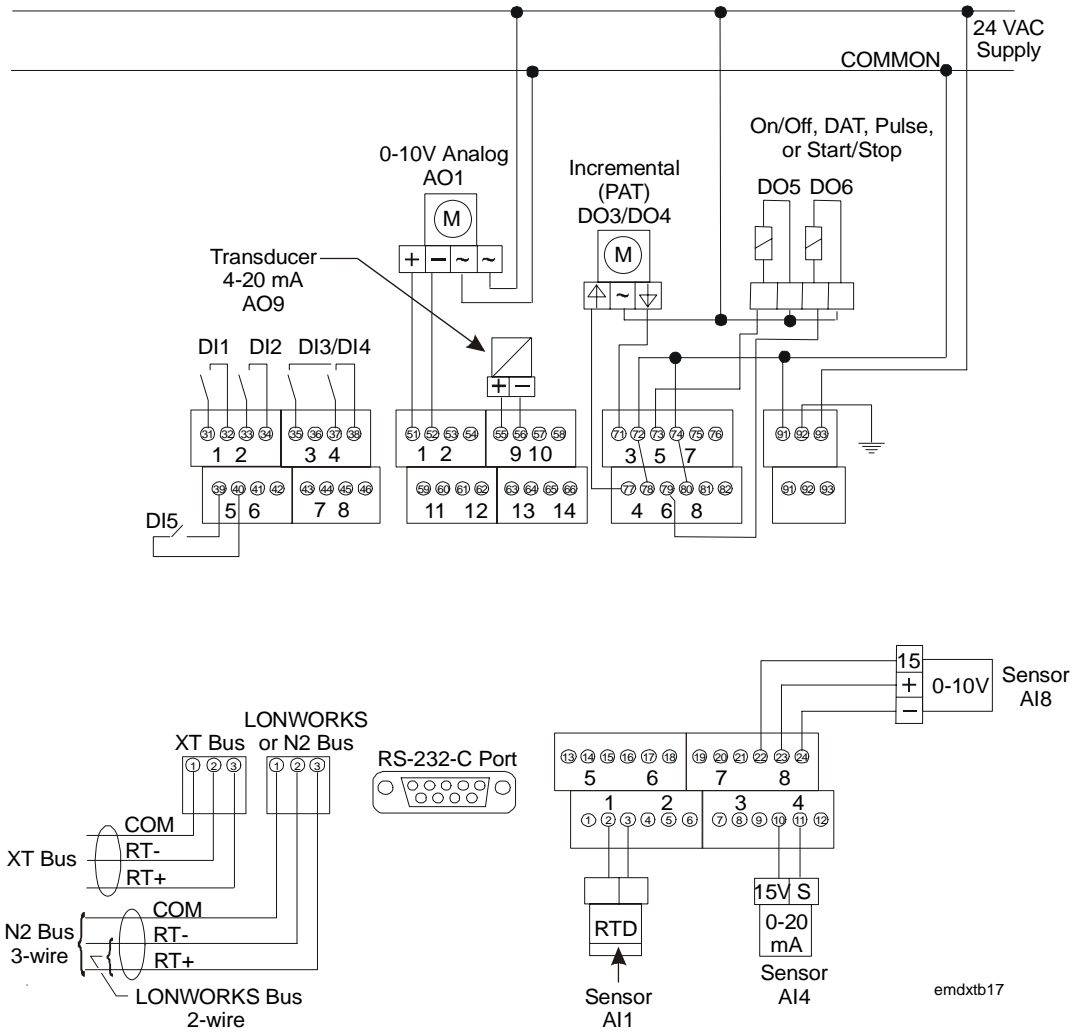

**Figure 24: Wiring Example for Versions 2 and 3
(Panel Mounting Base Terminals Shown)**

Note: The diagram shows the wiring using a common transformer for controller supply, and input and output devices. Separate transformers can be used.

General Wiring Guidelines

Every reasonable precaution has been taken to prevent electrical disturbances from adversely affecting the operation of the controller, and the controller complies with appropriate local codes for Electromagnetic Compatibility (EMC). However, lack of attention to generally accepted control wiring installation practices can lead to controller problems in high electromagnetic field environments. In general, follow the guidelines below.

- Do not mount the controller in heavy duty switch gear cabinets or in cabinets with frequency-converting or phase-cutting equipment.
- Low voltage wiring in electrical cabinets must be physically separated from line voltage and power wiring, and a distinctive color of wire (e.g., white or pink) is recommended.
- To avoid electrical interference in field cables:
 - Keep input and output point cable runs as short as possible (less than 50 m [165 ft]).
 - Use twisted pair cables.
 - Run low voltage cables separately from line voltage/power cables, and use a minimum of 30 cm (12 in.) separation for 230V 30A circuits.
 - Do not run low voltage cables parallel to power cables for long distances (greater than 3 m [10 ft]).
 - Do not run cables close to transformers or high frequency generating equipment.
 - In high electromagnetic field environments, use shielded cable, grounding the drain wire at the controller cabinet only.
 - Use a cable recommended for RS-485 transmission for the N2 Bus (Bus 91) (communications buses), and the XT Bus (extension module bus). If the cable is shielded, it must be grounded at one point only (normally at one end of the bus). (See the technical bulletin on the N2 Bus or System 91 Bus Converter and Repeater). If a 2-wire cable is installed, the shield may be used for the RS-485 common (or reference) signal.
 - For the LONWORKS communications bus, use a balanced 110 ohm twisted pair cable. If the cable is shielded, it must be grounded at one point only (normally at one end of the bus).
- Do not connect switched inductive loads to the 24V transformer, which supplies the controller. When multiple loads are connected to one transformer, cable each connected load from the transformer separately so that any possible disturbances from one load will have minimal affect on other loads.

Figure 25 shows the correct way to wire the controller to the transformer. Figure 26 illustrates the incorrect way.

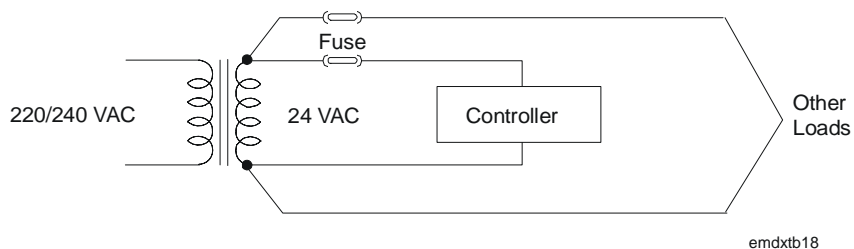

Figure 25: Correct Wiring of Controller to 24V Transformer

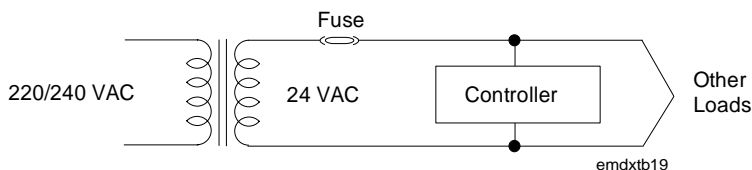

Figure 26: Incorrect Wiring of Controller to 24V Transformer

Battery Replacement

The controller has a rechargeable capacitive battery and a non-rechargeable lithium battery. The capacitive battery is charged by connecting the controller to 24 VAC for a minimum of one hour. It will maintain the contents of the Random Access Memory (RAM) for up to seven days. The lithium battery provides RAM backup for at least one year at room temperature without external power.

When the lithium battery has less than 20% of its full charge and the controller has 24 VAC power, the battery LED on the front panel flashes to indicate that the battery should be changed.

Configuration and calibration data is stored in EEPROM and is not lost upon 24 VAC power failure or battery failure. However, if 24 VAC power, capacitive battery charge, and lithium battery charge are lost, the controller will lose all realtime operating data stored in RAM, such as the realtime clock, counter values, and supervisory control modes. These values must be set in the controller again when battery or 24 VAC power has been restored.

Lithium Battery

To replace the lithium battery, proceed as follows:

Version 1

Switch off the 24 VAC power supply and open the controller as described under *Mounting Instructions*. The lithium battery is located on the upper board behind the display panel. Carefully cut the nylon tie and remove the old battery. Insert the new battery, observing the correct polarity. Secure it with the new nylon tie supplied with the battery. Reattach the controller cover to the base and tighten the retaining Screw A (see Figure 4).

Note: Each controller is sent from the factory with the lithium battery jumper in the On position.

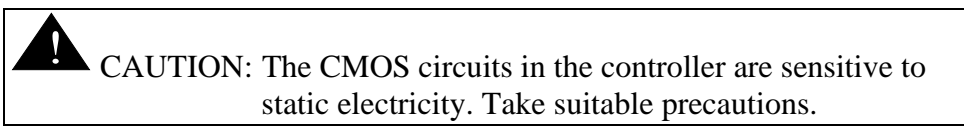

Versions 2 and 3

Remove the controller from its base as described under Version 2 and 3 *Mounting Instructions*. Remove the two retaining screws from the back of the controller to open it. See the figure below.

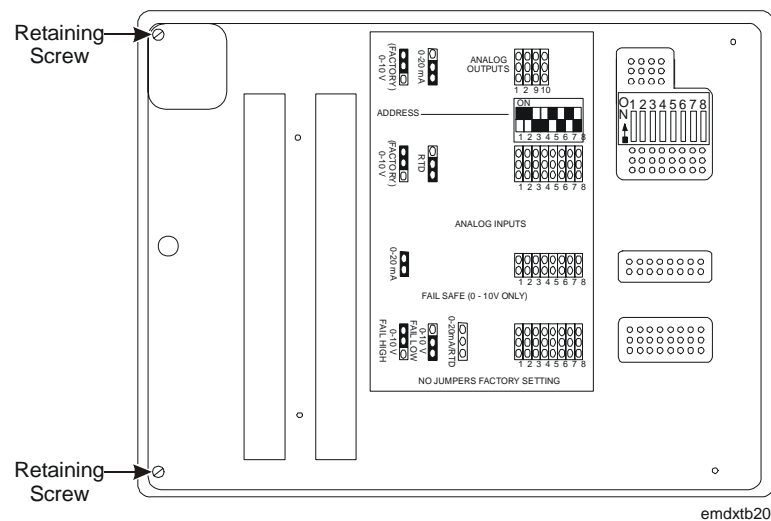

Figure 27: Retaining Screws on the Back of the Version 2 or 3 Controller

Place the controller on a flat surface and separate the two half shells of the controller, taking care not to damage the connecting cables. The lithium battery is located on the upper board behind the display panel, as shown in Figure 28. Carefully cut the nylon tie and remove the old battery. Insert the new battery, observing the correct polarity. Secure it with the new nylon tie supplied with the battery. Reassemble the controller, ensuring that the front panel is securely on the base and that the retaining screws are tight. Replace the controller on the base and tighten Retaining Screw C. See Figure 13 and Figure 15.

Note: Each controller is sent from the factory with the lithium battery jumper in the On position. The jumper should only be set to Off if the controller is to be kept in storage without power for an extended period of time. The jumper must be set to On before the controller is installed and powered up.

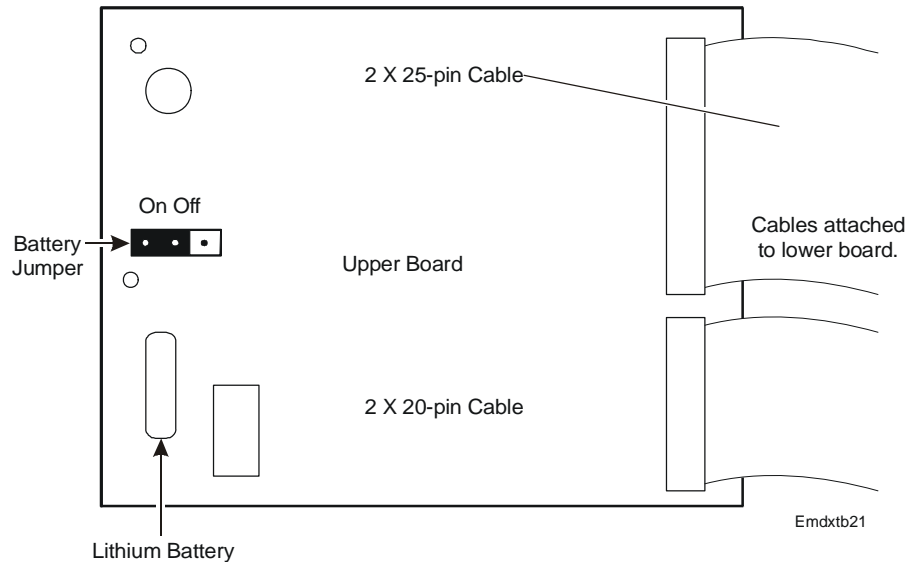



Figure 28: Replacing the Lithium Battery in the Version 2 or 3 Controller

 **CAUTION:** The CMOS circuits in the controller are sensitive to static electricity. Take suitable precautions.

Startup

When all jumpers and address switches have been set, and all connections have been made to the controller and checked for correct voltage and current signal levels, 24 VAC power may be applied to the controller.

During startup, `init` will appear on the front panel. Then the version level of the firmware in the controller will be displayed, followed by the number, if any, of the configuration that has already been loaded into the controller. See *Startup Mode* under *Display Panel and Keypads*.

If no version number is displayed, the controller will have Version 1 firmware.

If the controller has already been loaded, it begins control operations automatically. Otherwise, the controller is now ready to receive a configuration via its N2 Bus (Bus 91) or RS-232-C communication port.

All these controller versions (Version 1 with Version 1.1 or later firmware) may be downloaded from the Metasys Operator Workstation (OWS).

Inputs/Outputs

Analog Inputs

The DX-9100 accepts eight analog inputs, each of which may be 0-10V, 0-20 mA, or passive RTD sensor by jumper configuration. For 0-20 mA inputs, a zero offset to 4 mA may be set by software configuration. The measurement unit for passive (RTD) inputs is configured for degrees Celsius or degrees Fahrenheit to enable the controller to convert the measured resistance according to the appropriate temperature scale.

In *Version 1* of the controller, measurement units of Celsius, Fahrenheit, or percent may be selected for active inputs to enable the appropriate LED to be lit on the front panel. (Versions 2 and 3 do not have these LEDs.)

These active inputs (voltage or current) are ranged using the programmable range parameters as follows:

- Lower end of range (LR) for 0V/0 mA/4 mA
- Higher end of range (HR) for 10V/20 mA

Voltage and current inputs from differential pressure transducers can be linearized by a square root function, which operates over the complete range of the input.

$$AI = \sqrt{\frac{\%PR}{100}} (HR - LR) + LR$$

Where: %PR = the analog value in percent of the physical range
(0-10V, 0-20 mA, 4-20 mA)

A configurable filter constant in seconds is incorporated for the reduction of signal instability.

In addition, the DX-9100 will accept Ni1000 (Johnson Controls and DIN characteristics), Pt1000, and A99 passive RTD sensors. For these sensors, the measurement range is fixed. The programmable range must only be set to determine the range of control when the input is connected to a control module.

The DX-9100 provides the 15 VDC supply for active analog input sensors.

Note: The maximum current supplied from this power supply must not exceed 100 mA in the *Version 1* controller and must not exceed 200 mA in the *Version 2* or *3* controller for current (0-20 mA and 4-20 mA) transmitters. A maximum of 80 mA may be used for voltage transmitters or other devices that take the current from the 15 VDC supply but do not return the current via the analog input terminal.

Each of the analog inputs can be assigned to any of the 12 programmable function modules.

A high and low limit setting can also be assigned to each of the analog inputs. By utilizing the startup and shutoff module commands, timer function modules and the alarm disable function, it is possible to inhibit these high and low alarms on plant startup or shutdown while retaining any alarm that is present when these commands are initiated.

Digital Inputs

The DX-9100 accepts eight digital input signals. A digital input is active (true) when connected to the digital input common via an external potential-free contact. Each of the digital inputs can be assigned as inputs to any of the 12 programmable function modules or to the programmed logic control module.

Digital Counters

Each digital input has an associated digital counter. The number of positive transitions of the physical digital input required to increment the counter can be programmed in the controller. The maximum value of each counter can be configured as 9,999,999 or 32,767 (15 bits) for FMSs, such as Metasys, which read 15-bit counter data.

Analog Outputs

The analog output modules of the DX-9100 provide the interface between the hardware analog outputs and the outputs of the programmable function modules. Each of the analog outputs can be ranged to give a 0-100% output between a low range (LRO) and high range (HRO) input value.

Each analog output module is therefore configurable with three parameters and can carry out the following functions:

$$\text{For } LRO < I < HRO, \text{ the Output} = \frac{I - LRO}{HRO - LRO} \times 100\%$$

For I less than LRO, the Output = 0%

For I greater than HRO, the Output = 100%

Where:

I = Input variable from one of the programmable function modules.

LRO = Low range variable corresponding to the module input value that requires the hardware output to be at 0% (0V, 0 mA, or 4 mA by configuration).

HRO = High range variable corresponding to the module input value that requires the hardware output to be at 100% (10V or 20 mA by configuration).

The actual output signal can also be limited by a high limit (HLO) and a low limit (LLO) value:

For Output less than LLO, Output = LLO

For Output greater than HLO, Output = HLO

Each analog output module may be put in Hold mode and its output value modified via an FMS.

Version 1 (DX-9100-8154) provides two analog outputs, which can be set to 0-10V or 0-20 mA by jumper configuration (see Figure 9), and which can have a 4 mA zero offset by software configuration.

Version 2 (DX-9100-8454 or FA-DX9100-8454) and **Version 3 (DX-912x-8454)** each provide four analog outputs, which can be set to 0-10 V or 0-20 mA by jumper configuration (see Figure 22), and which can have a 4 mA zero offset by software configuration, and an additional four outputs that are 0-10V only.

Digital Outputs

The six logic output modules are used to configure the six digital outputs (24 VAC triacs) of the DX-9100. Alternatively, a digital output may be enabled for FMS control only.

The output modules provide the interface between the hardware digital outputs (triacs) and the outputs (logic or numeric variables) from the programmable function modules, programmable logic control module, or time scheduling modules. Any of these modules may be assigned to any of the logic output modules, and in turn each of the logic output modules controls its output triac.

A logic module may be put into Hold mode and its output value modified via an FMS.

Each logic output module can be configured to provide one of the following output types:

- On/off (driven from a logic variable)

The triac is switched on or off by a change-of-state of the logic variable.

- On/off (driven from a numeric variable)

The triac is switched on or off as a function of the output of a programmable function module (positive output = On, 0 or negative output = Off).

- **Duration Adjusted Type (DAT) (driven from a numeric variable)**

The triac is driven open or closed with a time base duty cycle that is proportional to the numeric output of a programmable function module. The DAT output can be ranged to give 0-100% duty cycle between a low range (LRO) and high range (HRO) value of the controlling variable.

A minimum on/off time in percent of the time base may be set to avoid very short on pulses at the low range value (output at 0%) and very short off pulses at the high range value (output at 100%).
- **Position Adjust Type (PAT, incremental control), without feedback (driven from a numeric variable)**

A pair of triacs, (two adjacent output modules) can be used as a Position Adjust Type (PAT) output to operate a synchronous reversible electric actuator.

PAT output gives modulating control by reference to the programmed actuator total runtime (fully open to fully closed), and drives the actuator for a part of that time base in proportion to the change in the controlling numeric variable. For example, for a 120 second actuator to achieve 40% open, the actuator will run for 48 seconds from a fully closed position.

A deadband, in percent of total runtime, may be set to avoid driving the actuator for very small changes in the output signal, thus reducing unnecessary wear on the drive mechanism.

The output can be programmed to give 0-100% between a low range (LRO) and high range (HRO) of the value of the controlling variable.

The travel of the actuator may be limited by entering low and high limits for the output signal (LLO and HLO).

A PAT output requires two output modules. The triac of the output module, which is programmed as a PAT type, will be switched on when the output must increase. The next output module (in numerical sequence) cannot be used for any other output function, and its triac will be switched on when the output must decrease. Modules 3/4, 4/5, 5/6, 6/7, and 7/8 can be used as PAT type output.

When a PAT module is at 0% or 100%, the appropriate output triac will switch on for the full stroke time every two hours.

- PAT with feedback (driven from a numeric variable)
This output is identical to the above with the exception that a 0-100% analog position feedback signal is input into the controller and the actuator is driven in the appropriate direction until the position feedback signal is equal to the controlling variable position signal plus or minus the deadband value. A logic variable, which can be used for information or control purposes, is set if the feedback signal does not change when the actuator is driven in either direction.
- Start/Stop (S/S) (driven from a logic variable).
A pair of triacs (two adjacent output modules) can be used as a start/stop output to operate an external latching circuit which controls the starting and stopping of a pump, fan, etc. A start/stop output requires two output modules.
The triac of the output module, which is programmed as an S/S type, will be switched on for 1 second when the connected logic variable goes to State 1 (true). The next output module (in numerical sequence) must not be programmed and its triac will be switched on for 1 second when the connected logic variable goes to State 0 (false). Modules 3/4, 4/5, 5/6, 6/7, and 7/8 can be used as S/S type output.
- Pulse (driven from a logic variable).
(The triac is switched on for a period of 1 second for each state transition of the connected logic variable.)

***Analog/Digital
Constants and
Logic Result
Status***

There are 8 analog constants (ACO) and 32 digital constants (DCO), which can be used to store values set by the service module, front panel, or FMS. These constants can be used in the configuration in the same way as analog inputs, numeric variables, digital inputs, and logic variables.

There are 64 Logic Result Status (LRS) variables, which can be read by the service module or FMS, and are used in the Programmable Logic Control (PLC) module as program logic variables, partial logic results, or final logic results of logic routines. The logic result status variables can be used in the configuration in the same way as other logic variables.

Extension Modules

The input/output capacity of the DX-9100 controller may be extended by connecting up to eight extension modules via the XT Bus.

An extension module set comprises an XT-9100 or an XTM-905 extension module and one or more XP/XPx expansion modules. The expansion modules provide input/output capability for the extension modules.

The following expansion modules are available for the XT-9100 extension module:

- XP-9102: six analog inputs and two analog outputs
- XP-9103: eight digital outputs (triac)
- XP-9104: four digital inputs and four digital outputs (triac)
- XP-9105: eight digital inputs
- XP-9106: four digital outputs (relay) (Europe only)
- XP-9107: four digital outputs (relay) (North America)

Refer to the *XT-9100 Technical Bulletin (LIT-6364040)* for full details of these modules.

An XTM-905 may be combined with its expansion modules to provide the following configurations:

Table 3: Expansion Module Types Available for the XTM-905 Extension Module (North America)

Model	Analog Inputs	Analog Outputs	Binary Inputs	Binary Outputs
XPA-821-5	6	2	–	–
XPB-821-5	–	–	8	–
XPE-401-5	–	–	4	3 single state
XPE-404-5	–	–	4	4 (common supply)
XPL-401-5	–	–	4	3 single state
XPT-401-5	–	–	4	4
XPT-861-5	–	–	–	8

An XT-9100 or XTM-905 can be combined with its expansion modules to provide the following configurations:

- eight analog inputs/outputs
or
- eight digital inputs/outputs, with digital counters associated with the digital inputs
or
- eight analog inputs/outputs and eight digital inputs/outputs
or
- sixteen digital inputs/outputs, with digital counters associated with the digital inputs within the first eight input/output points

Note: When an extension module is configured with 16 inputs/outputs, it takes the place, in the DX-9100 database, of 2 extension modules with 8 inputs/outputs each. The DX-9100 can communicate with a maximum of 64 inputs and outputs.

Analog inputs to extension modules may be 0-10V, 0-20 mA, or passive RTD-NI1000 (Johnson Controls characteristic only), Pt1000, or A99 sensors.

Analog inputs to the XPA-421-5 module only may additionally be RTD-Ni1000 (L&G and DIN), Pt100 and Ni100 sensors, or a 5K ohm potentiometer.

Voltage and current inputs from differential pressure transducers can be linearized by a square root function. Each analog input can be assigned to any of the 12 programmable function modules, and high and low alarm settings can be entered to each analog input.

Digital inputs to extension modules are potential-free contacts. The input is active (true) when the contact is closed. Each digital input can be assigned to any of the 12 programmable function modules or to the programmable logic control module.

Digital counters are available in extension modules, which do not have analog inputs or outputs. Digital counters are associated with digital inputs only on the first eight BIs on the XT-9100 or XTM-905. The number of positive transitions of the physical digital input required to increment the counter can be programmed in the extension module.

Analog outputs in extension modules can be configured to provide 0-10V, 0-20 mA, or 4-20 mA, and can be connected to outputs of programmable function modules in the DX-9100 controller. The output is ranged by low range and high range variables to provide a 0-100% signal to the extension module.

Digital outputs in extension modules can only be configured as on/off or pulse type, and the physical output may be a triac or a relay contact. Pulse type outputs switch on for a configurable period (1 to 1275 ms) for each transition of the connected variable. The exceptions are the XPM-421-5, XPL-421-5, and XPE-421-5 modules with relay outputs, which operate according to the type of module and have no equivalence in the XT-9100 set of XP modules.

Extension modules do not have logic output modules to control the digital outputs.

The digital outputs may be driven by any logic variable or output of the programmable function modules or time schedule modules, or by Logic Result (LRS) variables set by the Programmable Logic Control (PLC) module.

Note: For further information about extension modules, refer to the *XT-9100 Technical Bulletin (LIT-6364040)*, the *XT-9100 Configuration Guide (LIT-6364050)*, and the *XTM-905 Extension Module, XPx-xxx Expansion Modules Technical Bulletin (LIT-6364210)*.

**Network
Inputs/Outputs
for Version 3,
LONWORKS
Only**

The DX-912x-8454 controller with the LONWORKS network interface can send and receive data over the network without an FMS. A peer-to-peer network may comprise up to 30 controllers. This is made possible by the LONWORKS network processor, which resides inside the controller and communicates with all other network processors on the same network. The network configures itself, reading each connected controller to determine if and when data should be transmitted. Both analog and digital data may be transmitted from one controller to another, and any one piece of data – one analog value or a block of 16 digital values - may be sent from one controller to up to 16 other controllers.

Data is received in a controller as network analog inputs and network digital inputs, and data is transmitted from network analog outputs and network digital outputs. The only parameters to define are the sources of the output values within the controller and the network destinations.

The Metasys NCM300 or NCM350 (NCM311 or NCM361 in Europe) may be connected to the network as an FMS but it acts only as a supervisory controller and does not take part in the exchange of data between controllers.

Analog Inputs

The Version 3 controller accepts 16 network analog inputs, each of which contains a numerical value received from a network analog output in another controller. These inputs can be used in the configuration in the same way as physical analog inputs, except that there are no parameters to define. The source of the analog data is defined in the transmitting controller. A typical application for a network analog input would be for receiving the value of the outdoor temperature from another controller.

Digital Inputs

The Version 3 controller accepts 8 network digital inputs, each of which contains 16 digital input logic values, received from a network digital output in another controller. Each of the 16 digital values in the digital input can be used in the configuration in the same way as physical digital inputs. The source of the digital data is defined in the transmitting controller. Digital data is always transmitted in blocks of 16 values from one controller to another and the block cannot be split apart by the network. Not all 16 values need to be used, and within the controller the values can be used independently. A typical application for a network digital input might be for receiving operating status data by secondary equipment from a primary unit so that the secondary unit can start when the load is high or the primary unit fails.

Analog Outputs

The Version 3 controller has up to 16 network analog outputs, each of which may be configured to transmit a numerical value to a network analog input in another controller. These outputs receive their values from other inputs, outputs, constants, programmable function modules, or extension module inputs of the same controller. Each network analog output may send its value to up to 16 other controllers. If 1 controller has an outdoor temperature input, for example, this input can be connected to a network output and sent to 16 other controllers, or connected to 2 network outputs and sent to 29 other controllers. (A maximum of 30 controllers is allowed on one LONWORKS network).

Digital Outputs

The Version 3 controller has up to 8 network digital outputs, each of which may be configured to transmit 16 digital values to a network digital input in another controller. Each of the 16 digital values in the digital output receives its value from another digital input, output, constant, logic result status, programmable function module, time scheduling module, or extension module input of the same controller. Each network digital output may send its 16 digital values as a block to up to 16 other controllers. If one controller has been configured to determine the occupancy status of an area, for example, a network output could be used to give this information to, say, three other controllers in the same area.

Operation

Introduction

The DX-9100 provides realtime functions, 12 programmable function modules, and 1 programmable logic control module.

The realtime **functions** are dedicated to the management of all the features related to the calendar and the time information. The following realtime modules are implemented:

- eight Time Schedule Modules, each with eight on/off events
- two optimal start/stop modules

The function of **each programmable function module** depends on the algorithm selected for that module. The following programmable algorithms are implemented in the DX-9100 operating system:

- PID Controller
- On/Off Controller
- Heating/Cooling PID Controller (Dual PID)
- Heating/Cooling On/Off Controller (Dual On/Off)
- Average Calculation
- Minimum/Maximum Selection
- Psychrometric Calculation (Celsius/Fahrenheit)
- Line Segment Function (16 segment)
- Input Selector
- Calculator (Linear or Polynomial Equation)
- Timer Functions (8 Channels)
- Totalization (Event, Integration, Runtime) (8 Channels)
- Comparator (8 Channels)
- Sequencer (Up to 8 Output Stages)
- 4 Line Segment Functions (4 Functions with 4 Segments each)
- 8 Calculators (8 Channel with Simple Math Function)
- Trend Log

The function of the **programmable logic control** module depends on a user-entered program of up to 512 program lines, each containing a field for an instruction code. The following instruction codes are implemented in the DX-9100 operating system:

- AND/AND NOT Logic AND/AND NOT
- OR/OR NOT Logic OR/OR NOT
- ANDB Logic AND between logic blocks
- ORB Logic OR between logic blocks
- OUT/OUT NOT Result transfer/Inverted result transfer
- COS Change-of-state detection
- SET/RST SET state to 1/RESET state to 0

In the GX-9100 Graphic Configuration software, the program code is automatically generated from a graphic representation of the logic functions.

Realtime Functions

The realtime functions are based on a hardware realtime clock and on software tasks, which perform all the calendar and time functions, the daylight saving time changes, the day of the week definition, and the handling of holidays.

The realtime clock has a battery backup so it will retain the correct time during a power failure. The clock parameters (year, month, day, hour, minute) can be set from both the front panel and the FMS. The actual day of the week is automatically calculated from the calendar day during power up initialization and at every change of date.

A daylight saving function provides the automatic modification of the realtime clock, setting the time forward one hour when daylight saving time begins and setting the clock back one hour when it ends. The daylight saving period begins at time 00:00 on the begin date and terminates at 01:00 on the end date.

An Exception Day Table determines exceptions for the day of the week status. These exceptions are normally used to define holidays. The Exception Day Table comprises up to 30 entries, each of which defines a time period with a begin date and an end date. If the actual date is within an exception day time period, the day type is set to Holiday (or Day Type 8).

Time Schedule Modules

The eight time schedule modules each provide the control of a logic output as a function of a programmable start/stop schedule, the day of the week, exception days condition, and the realtime clock.

The time schedule module is executed each minute. If external forcing conditions are not present, the event schedule is examined to verify whether a start/stop command is programmed for the actual time and day of the week.

Three logic inputs can modify the normal behavior of the time schedule module according to the following priorities:

1. A forcing command sets the output to Off.
2. A forcing command sets the output to On.
3. An extension override command extends the occupancy period for a programmable time and is active only during occupancy time.

The extension override status of the module can also be controlled by a keyboard command or by a command from an FMS. When any one of the commands from the keyboard, FMS, or logic input are true, the extension override status of the module is true.

The time schedule module can contain up to eight events. Each entry contains the following information:

DAYS ENABLE: to select in which days of the week (1 = Mon, 2 = Tue, up to 8 = Holiday) the start/stop command is enabled; may be enabled for one or more days

START TIME: [Hour][Minute]

STOP TIME: [Hour][Minute]

The duration of a time programmed event can be extended to cover a period greater than one day by programming the stopping time of one event as 24:00 and the starting time of the next event as 00:00 on the next day.

A time schedule module may be put in Hold mode and its logic output modified via an FMS.

Optimal Start/Stop Modules

Two optimal start/stop modules each calculate the minimum time to bring a controlled zone temperature to a desired level at occupancy time under heating and/or cooling conditions. The modules also calculate the optimal stop time necessary to maintain the desired conditions to the end of the occupancy time.

The optimal start algorithm adapts as the heating and cooling thermal characteristics of the building are measured during the preheating or precooling cycles. The algorithm optionally compensates for outdoor temperatures above or below building design parameters.

The optimal stop algorithm uses the given heating and cooling characteristics and outdoor temperature at the time of plant shutdown. If the outdoor temperature is not connected, the optimal Stop mode is automatically disabled. The optimal start modules are defined by the following parameters:

- Zone Temperature
- Outdoor Temperature
- Zone Temperature On Setpoint (20)* [°C] or (68)* [°F]
- Zone Temperature Stop mode (Off) Bias (-3)* [°C] or (-6)* [°F]
- Time Schedule Module connections
- External Disable Signal to the Adapting Algorithm
- External Disable Signal to the Module
- Module type: Heating, Cooling, Heating and Cooling
- Minimum Heat/Cool Time (20)* [minutes]
- Maximum Startup Time (240)* [minutes]
- Maximum Optimal Stop Time (240)* [minutes]
- Start Mode Building Heating Factor (5)* [min/°C²]
or (1)* [min/°F²]
- Start Mode Building Cooling Factor (5)* [min/°C²] or
(1)* [min/°F²]
- Stop Mode Building Heating Factor (100)* [min/°C/°C]
or (100)* [min/°F/°F]
- Stop Mode Building Cooling Factor (100)* [min/°C/°C] or
(100)* [min/°F/°F]
- Adaptive Control (Filter Weight) (10)* [%]
- Outdoor Air Design Temperature
Heating (-10)* [°C] or (14)* [°F]

- Outdoor Air Design Temperature
Cooling (30)* [°C] or (86)* [°F]
- Control Range (+/-) (2)* [°C] or (4)* [°F]

* Default value in the Graphic Configuration software.

The parameters Zone Temperature On Setpoint and Zone Temperature Off Setpoint Bias may be set as fixed values or they may be connected to other numerical values in the configuration.

Optimal Start Adaptive Process

The adaptive process monitors how quickly the temperature reaches the halfway point between the setpoint and actual temperature:

- If it takes less than the calculated warmup time based on the building factor, then the building factor will be decreased so that the next calculation will result in a shorter warmup time, all other factors being equal.
- If it takes more than the calculated warmup time based on the building factor, then the building factor will be increased so that the next calculation will result in a longer warmup time, all other factors being equal.

The adaptive process calculation only takes place when the Optimal Start mode actually starts the plant.

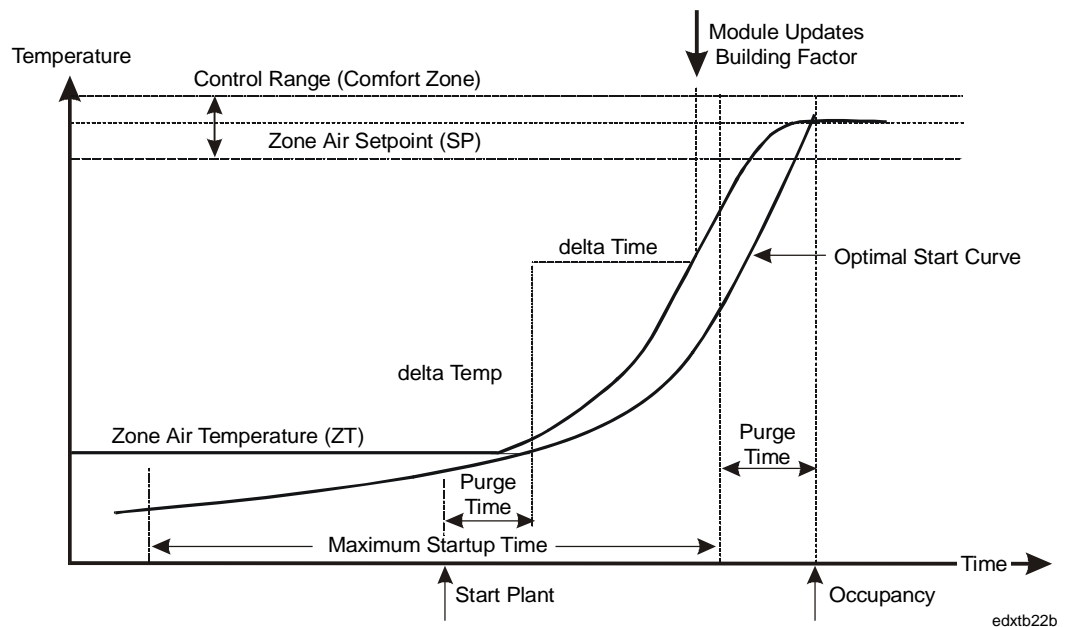

Figure 29: Optimal Start Module in Heating Mode

$$\text{Warmup Time} = \text{Heating Factor} \times (\text{SP} - \text{ZT} + \text{TC})^2 + \text{PT}$$

$$\text{TC} = (\text{HTD} - \text{OT})/4 \text{ when HTD is greater than OT, else TC} = 0$$

$$\text{Cooldown Time} = \text{Cooling Factor} \times (\text{ZT} - \text{SP} + \text{TC})^2 + \text{PT}$$

$$\text{TC} = (\text{OT} - \text{CTD})/4 \text{ when OT is greater than CTD, else TC} = 0$$

When the Zone Air Temperature has risen halfway towards the Zone Setpoint, the module updates the Building Factor value using the following calculation:

$$\text{NBF} = \frac{(100 - \text{FW}) \times \text{OF} + \text{FW} \times \text{delta Time}/(\text{delta Temp})^2}{100}$$

The Building Factor is not updated if the initial Zone Air Temperature is within the Control Range, or the Outdoor Temperature is outside of design values.

- | | |
|------------------------------|---------------------------------------|
| NBF = New Building Factor | PT = Min. Heat/Cool Time (Purge Time) |
| FW = Filter Weight | HTD = Outdoor Design Temp. Heating |
| OF = Old Factor | CTD = Outdoor Design Temp. Cooling |
| SP = Zone Air Setpoint Temp. | TC = Temperature Compensation |
| ZT = Zone Air Temperature | OT = Outdoor Temperature |

Optimal Stop Operation

If the difference between the outdoor air and the zone temperature is small, the heating equipment can be stopped at an earlier time than if the difference is large.

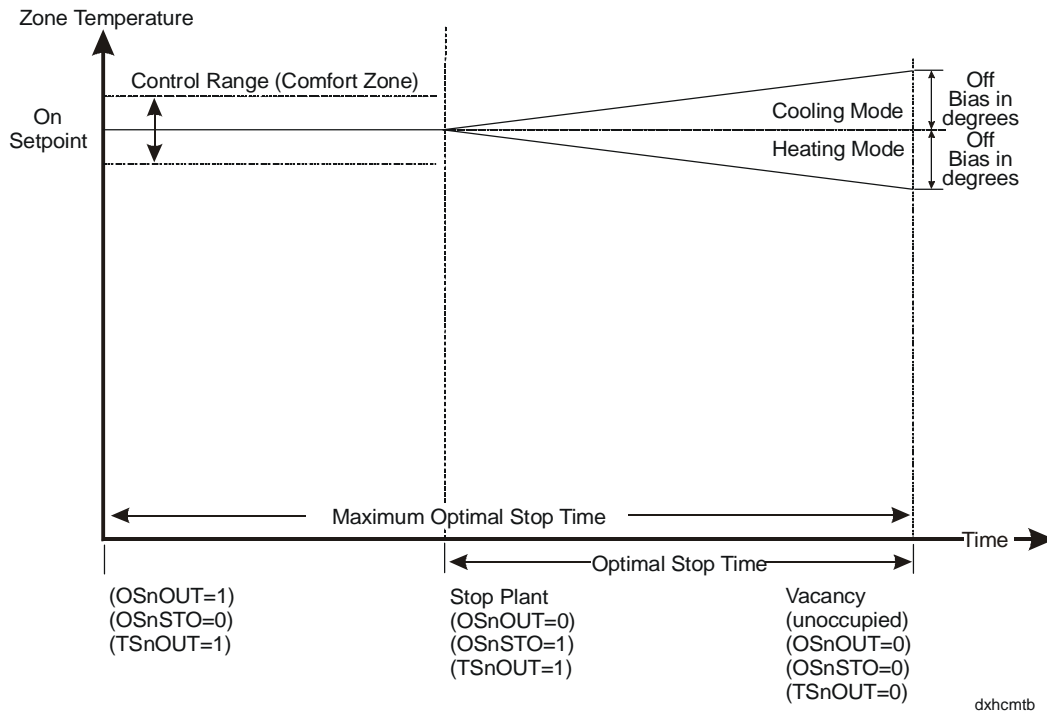

Figure 30: Optimal Stop Module in Heating/Cooling Mode

$$\text{Optimal Stop Time} = \frac{\text{Zone Temp. Off Bias} * \text{Shutdown Building Htg/Clg Factor}}{\text{Zone Temp.} - \text{Outdoor Temp.}}$$

or = Maximum Optimal Stop Time
(whichever is least)

If the Zone Temperature (ZT) is not within the Control Range (CRNG), or Outdoor Temperature (OT) is not connected, the Optimal Stop algorithm is not executed and the output **OSnOUT** is reset at the vacancy time (i.e., the Optimal Stop Time set at 0).

**Programmable
Function
Modules:
Control
Algorithms**

The DX-9100 has four control algorithms:

- PID Controller
- On/Off Controller
- Heating/Cooling PID Controller (Dual PID)
- Heating/Cooling On/Off Controller (Dual On/Off)

Each algorithm can be used in 1 of the 12 programmable function modules.

The four algorithms have a number of operating modes, which are a function of the operating parameters and digital inputs. These operating modes are as follows:

- **Comfort Mode:** This is used to obtain the desired space temperature typically during occupancy. The setpoints in this mode mark the beginning of demand for heating or cooling. The output is calculated by the control algorithm using the following value as the working setpoint (WSP):

$$\text{WSP} = \text{RV} \times (\text{LSP} + \text{RSP})$$

- **Standby Mode:** When operating in this mode, the controller setpoint is reduced or increased during heating or cooling, respectively, when it is compared with the Comfort mode setpoint. This mode is typically selected for brief periods when the controlled zone is unoccupied in order to save energy. The output is calculated by the control algorithm using the following value as the working setpoint:

$$\text{WSP} = \text{RV} \times (\text{LSP} + \text{RSP}) + \text{BSB}$$

- **Off Mode:** This is similar to the Standby mode, but the setpoint is further reduced or increased when the controlled zone is unoccupied for long periods. This mode is typically selected for nights, weekends, vacations, etc. The output is calculated by the control algorithm using following value as the working setpoint:

$$WSP = RV \times (LSP + RSP) + BOF$$

- **External Forcing Mode:** The control module output assumes a configured value, overriding the output limits of the control module.

The above modes can be selected through digital inputs or through digital constants, depending on the configuration.

In *Version 1.1 or later* of the DX-9100, high and low limit values for WSP can be set in the configuration to limit the calculated value for WSP and any overridden value of WSP to within an acceptable working range.

Once a DX-9100 control module is set to receive information from an FMS it can, in addition to the above, assume one or more of the following operating modes:

- **CMP** Computer mode (working setpoint is no longer calculated by the algorithm, but is set by the FMS).
- **REM** Remote mode (working setpoint is determined only by the remote setpoint).
- **HLD** Hold mode (module output value is no longer calculated by the algorithm, and may be overridden by the FMS).
- **STA** Startup mode (set by the FMS when STAE Startup Mode Enabled is set).
- **SOF** Shutoff mode (set by the FMS when SOFE Shutoff Mode Enabled is set).

In Startup or Shutoff mode, the control module assumes a configured value overriding the output limits of the control module.

When the DX-9100 is not in Computer mode, the Working Setpoint (WSP) is dynamically calculated using the following formula:

$$WSP = RV \times (LSP + RSP) + BIAS$$

where the BIAS value is dependent on the operating mode.

In Remote mode, the local setpoint (LSP) is set to zero.

In Hold mode, the control module output (OCM) is not updated by the control algorithm.

Algorithm 1 - PID Control

Each of the 12 programmable function modules can be defined as a PID (Proportional, Integral, and Derivative) control module. The proportional control module generates an **output (OCM)** ranging between 0 and 100% by comparing the Process Variable (PV) with the Working Setpoint (WSP) and the Proportional Band (PB).

During configuration the **Proportional Band (PB)** is entered as a percentage of the programmed range of the PV. It determines the operating range of the control module. A positive value for a PB selects direct acting and a negative value for a PB selects reverse acting. For example, a PV input range of 0-40°C and a PB setting of 15% result in a direct acting controller with a proportional band of 6 Kelvin. When the PV does not have a programmed range (PV@ is not connected to an analog input) a range of 0-100 is assumed.

The PI, PD, or PID action of a control module is determined by setting the appropriate values of reset action (TI) and rate action (TD) in the control module settings.

The **reset action (TI)** represents the integral time and is definable between 0 and 60 repeats per minute. A value of 0 disables the integral action.

$$\text{Integral action time } \mathbf{T_n} = 1/\mathbf{TI} \text{ minutes}$$

The **rate action (TD)** represents the derivative action decay time and is definable between 0 and 5 minutes. A value of 0 disables the derivative action.

The controller output can be generally described by a three zone function: two static zones defined by a low limit (LOL) and a high limit (HIL), and a dynamic zone where the output is the function of proportional band, reset action and rate action.

The output connects directly to an output module, or use as an input to one or more programmable function modules (for example, to obtain cascade control).

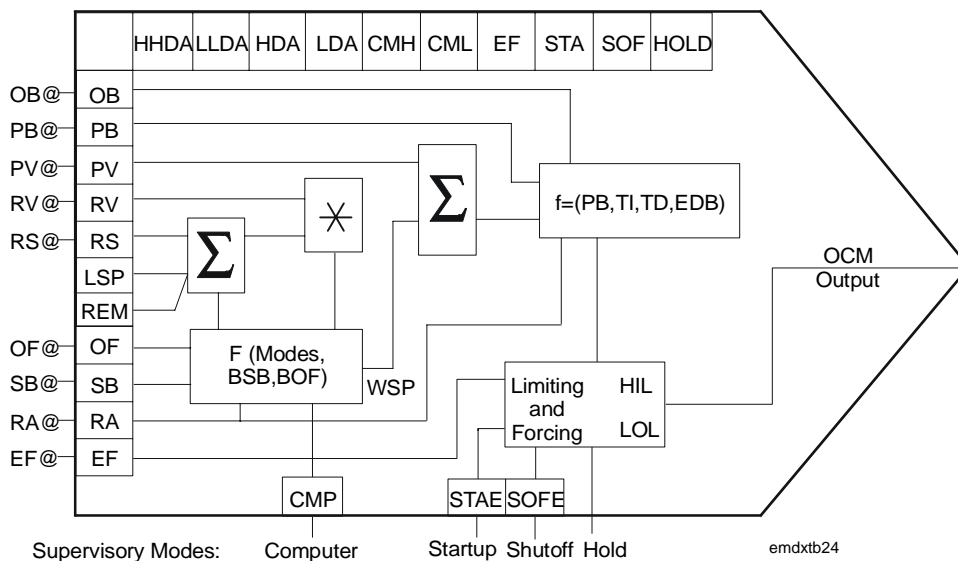

Figure 31: Control Module Block Diagram

Control Module Inputs and Outputs

The PID algorithm can be configured by using a number of analog and logic variables. As part of its operating function, it also provides a number of logical outputs to be used for interlocking or alarm purposes. Below is a list of these variables:

Numeric Input Variable Connections

- **PB@** defines the source of the proportional band. If the input is not connected, the internal value **PB** is used.
- **PV@** defines the source of the process variable. It is typically a pressure, temperature, or humidity input which, as it varies, causes the control module to change its output according to its PID transfer function.
- **RV@** defines the source of the reference variable. This input causes the control module to perform as a ratio controller. Its effect is a multiplication factor in the working setpoint calculation. If not connected, a default value of 1 is assumed.
- **RS@** defines the source of a remote setpoint. This input produces a bias on the local setpoint. If not connected, a default value of 0 is assumed.
- **OB@** defines the source of the output bias. If the input is not connected, the internal value **OB** is used.

Logic Input Variable Connections

- **OF@** defines the source of a digital input that will force the control module to the Off mode. If not connected, the Off mode is disabled.
- **SB@** defines the source of the digital input that will put the control module to the Standby mode. If not connected, the Standby mode is disabled.
- **RA@** defines the source of the digital input that will cause the control module action to be reversed. If not connected, the control action change function is disabled.
- **EF@** defines the source of the digital input that forces the control module to the External Forcing mode. If not connected, the function is disabled.

Logic Output States

- **CMH**: Output of control module has reached its high limit.
- **CML**: Output of control module has reached its low limit.
- **HHDA**: High High Deviation Alarm. (PV - WSP) is greater than the high high deviation alarm value.
- **HDA**: High Deviation Alarm. (PV - WSP) is greater than the high deviation alarm value.
- **LDA**: Low Deviation Alarm. (WSP - PV) is greater than the low deviation alarm value.
- **LLDA**: Low Low Deviation Alarm. (WSP - PV) is greater than the low low deviation alarm value.
- **EF**: When this state is on, the module is being externally forced.
- **STA**: When this state is on, the module is in Startup mode.
- **SOF**: When this state is on, the module is in Shutoff mode.
- **HLD**: When this state is on, the module is in Hold mode.
- **CMP**: When this state is on, the module is in Computer mode.
- **OF**: When this state is on, the module is in Off mode.
- **SB**: When this state is on, the module is in Standby mode.
- **RA**: When this state is on, the module is in Reverse Action mode.

Once the various inputs have been assigned to the control module, its operation will be determined using the following parameters:

- **LSP:** Local Setpoint. A value in the engineering unit of the PV (°C, °F, %, etc.) representing the basic setpoint of the control module. It is normally used to set the desired temperature, humidity or pressure of the controlled zone.
- **PB:** Proportional Band
- **TI:** Reset Action (PI, PID)
- **TD:** Rate Action (PD, PID)
- **BSB:** Standby Bias. Represents the shift of the WSP when the control module is operating in the Standby mode.
- **BOF:** Off Bias. Represents the shift of the WSP when the control module is operating in the Off mode. It normally represents the anti-condensation or night setpoint.
- **EDB:** Error Deadband. Expressed in % of proportional band. When the control variation (PV-WSP) is smaller than the Error Deadband, then the integral action of the controller is not active.
- **DHH:** Deviation High High Alarm Limit Value
- **DH:** Deviation High Alarm Limit Value
- **DL:** Deviation Low Alarm Limit Value
- **DLL:** Deviation Low Low Alarm Limit Value
- **HIL:** Upper limit of the controller output OCM
- **LOL:** Lower limit of the controller output OCM
- **OB:** Output Bias. Represents a constant value, which is added to the controller output OCM.

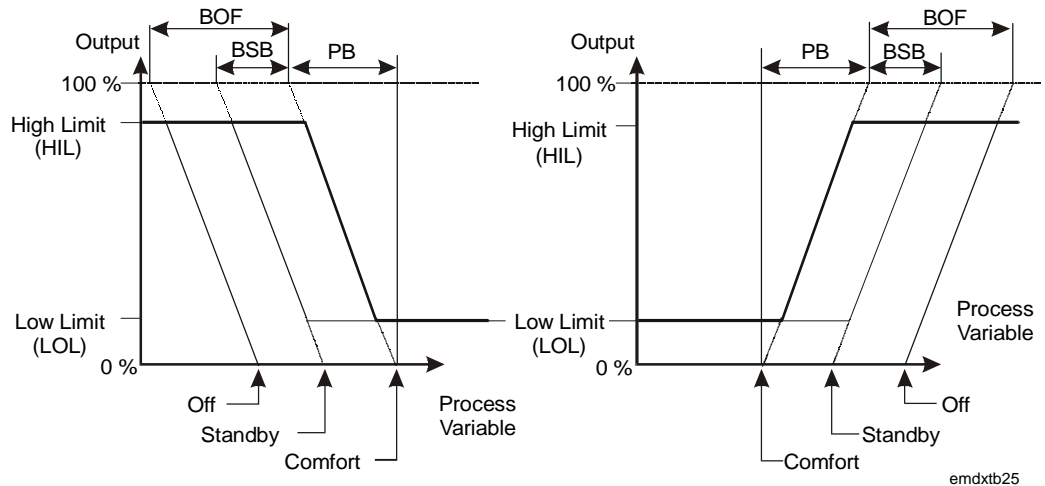

Figure 32: Reverse Acting Controller/Direct Acting Controller

Symmetrical Action

The control algorithm can be configured to operate as a controller with a symmetrical transfer function, where the cooling setpoint is calculated by adding a constant symmetry band to the heating setpoint and the control module output action is reversed. The settings and constants are the same as above with the addition of the symmetry band (**SBC**).

When the control module is operating in the Standby or Off mode, both heating and cooling setpoints are biased.

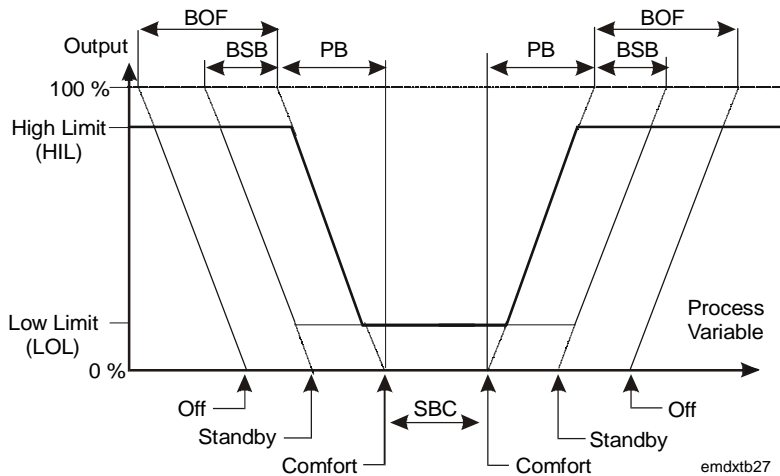

Figure 33: Controller with Symmetrical Operation (Proportional Controller Only)

Algorithm 2 - On/Off Control

Each of the 12 programmable function modules can be defined as an On/Off control module. The algorithm generates an output **OCM** (0 or 1) by comparing the Process Variable (PV) with the Working Setpoint (WSP) and the Action mode (ACT).

During configuration, enter the **Action mode (ACT)** as a positive or negative number. This determines the operating action of the control module. An ACT of “+1” selects direct acting and an ACT of “-1” selects reverse acting.

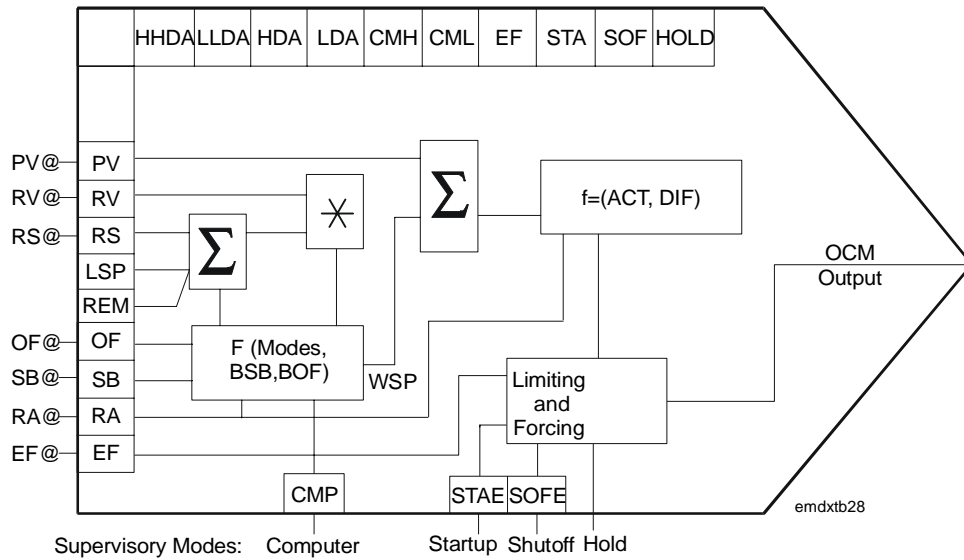

Figure 34: Control Module Block Diagram

Control Module Inputs and Outputs

The On/Off algorithm can be configured by using a number of analog and logic variables. As part of its operating function, it will also provide a number of logical outputs to be used for interlocking or alarm purposes. These variables are listed below.

Numeric Input Variable Connections

- **PV@** defines the source of the process variable. Typically a pressure, temperature, or humidity input which, as it varies, causes the control module to change its output according to its On/Off transfer function.
- **RV@** defines the source of the reference variable. This input causes the control module to perform as a ratio controller. Its effect is a multiplication factor in the working setpoint calculation. If not connected, a default value of 1 is assumed.
- **RS@** defines the source of a remote setpoint. This input produces a bias in the local setpoint. If not connected, a default value of 0 is assumed.

Logic Input Variable Connections

- **OF@** defines the source of a digital input that forces the control module to the Off mode. If not connected, the Off mode is disabled.
- **SB@** defines the source of the digital input that puts the control module to the Standby mode. If not connected, the Standby is disabled.
- **RA@** defines the source of the digital input that causes the control module action to be reversed. If not connected, the function is disabled.
- **EF@** defines the source of the digital input that forces the control module to the External Forcing mode. If not connected, the function is disabled.

Logic Output States

- **CMH**: Output of control module has reached its high limit.
- **CML**: Output of control module has reached its low limit.
- **HHDA**: High High Deviation Alarm. (PV - WSP) is greater than the high high deviation alarm value.
- **HDA**: High Deviation Alarm. (PV - WSP) is greater than the high deviation alarm value.
- **LDA**: Low Deviation Alarm. (WSP - PV) is greater than the low deviation alarm value.
- **LLDA**: Low Low Deviation Alarm. (WSP - PV) is greater than the low low deviation alarm value.
- **EF**: When this state is on, the module is being externally forced.
- **STA**: When this state is on, the module is in Startup mode.
- **SOF**: When this state is on, the module is in Shutoff mode.
- **HLD**: When this state is on, the module is in Hold mode.
- **CMP**: When this state is on, the module is in Computer mode.
- **OF**: When this state is on, the module is in Off mode.
- **SB**: When this state is on, the module is in Standby mode.
- **RA**: When this state is on, the module is in Reverse Action mode.

Once the various inputs have been assigned to the control module, its operation will be determined using the following parameters:

- **LSP:** Local Setpoint. A value in the engineering unit of the PV (°C, °F, %, etc.) representing the basic setpoint of the control module. It is normally used to set the desired temperature, humidity, or pressure of the controlled zone.
- **ACT:** Action mode
- **DIF:** Differential. Used to set the differential for on/off transitions.
- **BSB:** Standby Bias. Represents the shift of the WSP when the control module is operating in the Standby mode.
- **BOF:** Off Bias. Represents the shift of the WSP when the control module is operating in the Off mode. It normally represents the anti-condensation or night setpoint.
- **DHH:** Deviation High High Alarm Limit Value
- **DH:** Deviation High Alarm Limit Value
- **DL:** Deviation Low Alarm Limit Value
- **DLL:** Deviation Low Low Alarm Limit Value

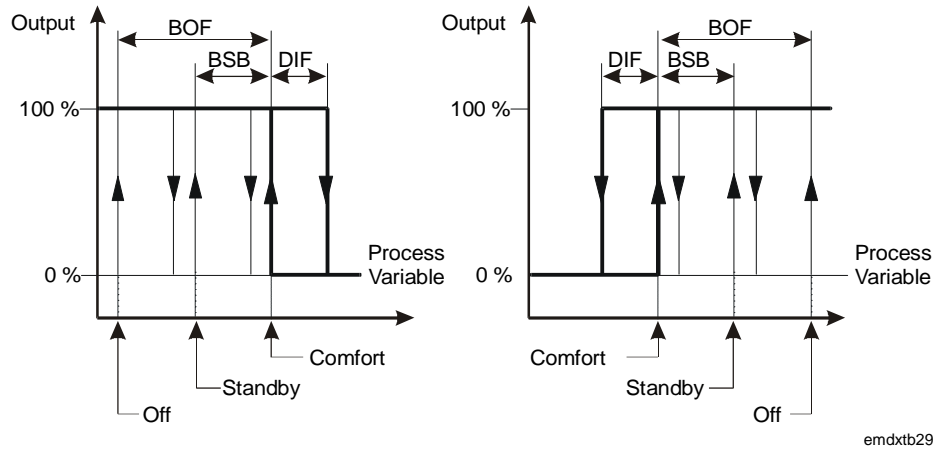

Figure 35: Reverse Acting Controller/Direct Acting Controller

Symmetrical Action

The control algorithm can be configured to operate as a controller with a symmetrical transfer function, where the cooling setpoint is calculated by adding a constant symmetry band to the heating setpoint and the control module output action is reversed. The settings and constants are the same as above with the addition of the symmetry band (SBC).

When the control module is operating in the Standby or Off modes, both heating and cooling setpoints are biased.

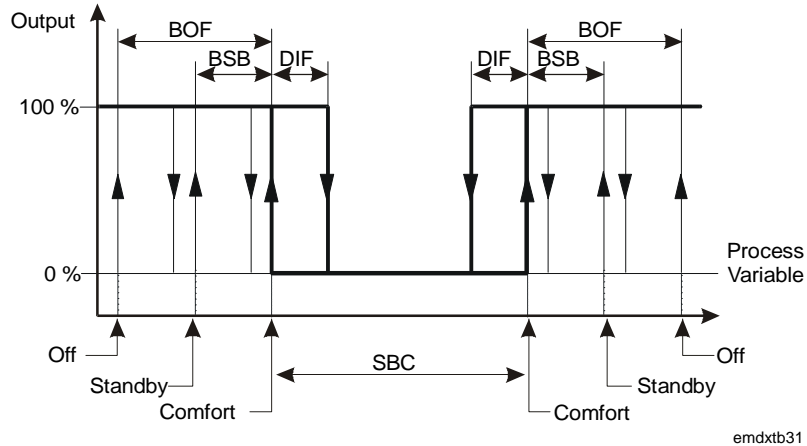

Figure 36: On/Off Controller with Symmetric Operation (ACT = -1)

Algorithm 3 - Heating/Cooling PID Control

Each of the 12 programmable function modules can be defined as a Heating/Cooling PID (Proportional, Integral, and Derivative) Control Module. The algorithm is implemented with two PID control loops sharing the same Process Variable (PV) and **Output (OCM)**. For **Version 1.1 or later** of the DX-9100 controller, the output of the heating control loop (**OCM1**) and the output of the cooling control loop (**OCM2**) are also available. The output ranges between 0 and 100%, comparing the process variable with a Working Setpoint (WSP) and the proportional band (PB1 and PB2) for each loop.

During configuration, the proportional bands **PB1** and **PB2** are entered as percentages of the programmed range of the PV and determine the operating ranges of the loops. A positive value of PB selects direct acting and a negative value of PB selects reverse acting. For the normal heating/cooling functions, PB1 is negative (-) and PB2 is positive (+). For example, a PV input range of 0-40°C and a PB setting of 15% results in a proportional band of 6 Kelvin. When the PV does not have a programmed range (PV@ is not connected to an analog input), a range of 0-100 is assumed.

The PI, PD, or PID action of a loop is determined by setting the appropriate values of reset action (TI1 and TI2) and rate action (TD1 and TD2) in the control module settings.

The **TI1** and **TI2** reset action represents the integral time and is definable between 0 and 60 repeats per minute. A value of 0 disables the integral action.

Integral action time **T_n** = **1/TI** minutes

The **TD1** and **TD2** rate action represents the derivative action decay time and is definable between 0 and 5 minutes. A value of 0 disables the derivative action.

The controller output can be generally described by a three zone function for each loop: two static zones defined by a low limit (LOL1 and LOL2) and a high limit (HIL1 and HIL2), and a dynamic zone where the output is the function of the respective proportional band, reset action, and rate action. The outputs can be connected directly to an output module, or used as an input to one or more other programmable function modules (for example, to obtain cascade control).

Control Module Inputs and Outputs

The Heating/Cooling PID algorithm can be configured by using a number of analog and logic variables. As part of its operating function, it also provides a number of logical outputs to be used for interlocking or alarm purposes. A list of these variables follows.

Numeric Input Variable Connections

- **PB@** defines the source of the proportional band. If the input is not connected, the internal value PB1 or PB2 is used.
- **PV@** defines the source of the process variable. Typically a pressure, temperature, or humidity input which, as it varies, causes the control module to change its output according to its PID transfer function.
- **RV1@/RV2@** defines the source of the reference variable or ratio for the respective loop. This input causes the control module to perform as a ratio controller. Its effect is a multiplication factor in the working setpoint calculation. If not connected, a default value of 1 is assumed.
- **RS1@/RS2@** defines the source of a remote setpoint for the respective loop. This input produces a bias on the local setpoint LSP1 or LSP2. If not connected, a default value of 0 is assumed.
- **OB1@/OB2@** defines the source of the output bias of the respective loop. If the input is not connected, the internal value OB1/OB2 is used.

Logic Input Variable Connections

- **OF@** defines the source of a digital input that forces the control module to the Off mode. If not connected, the Off mode is disabled.
- **SB@** defines the source of the digital input that puts the control module to the Standby mode. If not connected, the Standby mode is disabled.
- **RA@** defines the source of the digital input that causes the control module action to be reversed. If not connected, the control action change function is disabled.
- **EF@** defines the source of the digital input that forces the control module to the External Forcing mode. If not connected, the function is disabled.

Logic Output States

- **CMH**: Output of control module has reached its high limit. (Loop 1 or 2)
- **CML**: Output of control module has reached its low limit. (Loop 1 or 2)
- **HHDA**: High High Deviation Alarm. (PV - WSP) is greater than the high high deviation alarm value. (Loop 1 or 2)
- **HDA**: High Deviation Alarm. (PV - WSP) is greater than the high deviation alarm value. (Loop 1 or 2)
- **LDA**: Low Deviation Alarm. (WSP - PV) is greater than the low deviation alarm value. (Loop 1 or 2)
- **LLDA**: Low Low Deviation Alarm. (WSP - PV) is greater than the low low deviation alarm value. (Loop 1 or 2)
- **EF**: When this state is on, the module is being externally forced.
- **STA**: When this state is on, the module is in Startup mode.
- **SOF**: When this state is on, the module is in Shutoff mode.
- **HLD**: When this state is on, the module is in Hold mode.
- **CMP**: When this state is on, the module is in Computer mode.
- **OF**: When this state is on, the module is in Off mode.
- **SB**: When this state is on, the module is in Standby mode.
- **RA**: When this state is on, the module is in Reverse Action mode.
- **HEAT**: When this state is on, the module is in Heating mode.

Once the various inputs are assigned to the control module, its operation is determined using the following parameters for the respective control loops:

- **LSP1/LSP2:** Local Setpoint. A value in the engineering unit of the PV (°C, °F, %, etc.) representing the basic setpoint of the respective loop. It is normally used to set the desired temperature, humidity, or pressure of the controlled zone.
- **PB1/PB2:** Proportional Band. This parameter ranges from 0 to -100% for a heating loop, and from 0 to +100% for a cooling loop.
- **TI1/TI2:** Reset Action (PI, PID)
- **TD1/TD2:** Rate Action (PD, PID)
- **BSB1/BSB2:** Standby Bias. Represents the shift of the WSP when the loop is operating in the Standby mode.
- **BOF1/BOF2:** Off Bias. Represents the shift of the WSP when the loop is operating in the Off mode.
- **EDB1/EDB2:** Error Deadband. Expressed in % of proportional band. When the control variation (PV-WSP) is smaller than the error deadband then the integral action of the controller is not active.
- **DHH1/DHH2:** Deviation High High Alarm Limit Value
- **DH1/DH2:** Deviation High Alarm Limit Value
- **DL1/DL2:** Deviation Low Alarm Limit Value
- **DLL1/DLL2:** Deviation Low Low Alarm Limit Value
- **HIL1/HIL2:** Upper limit of the OCM controller output.
- **LOL1/LOL2:** Lower limit of the controller output OCM.
- **OB1/OB2:** Output Bias. Represents a constant value, which is added to the controller output OCM.

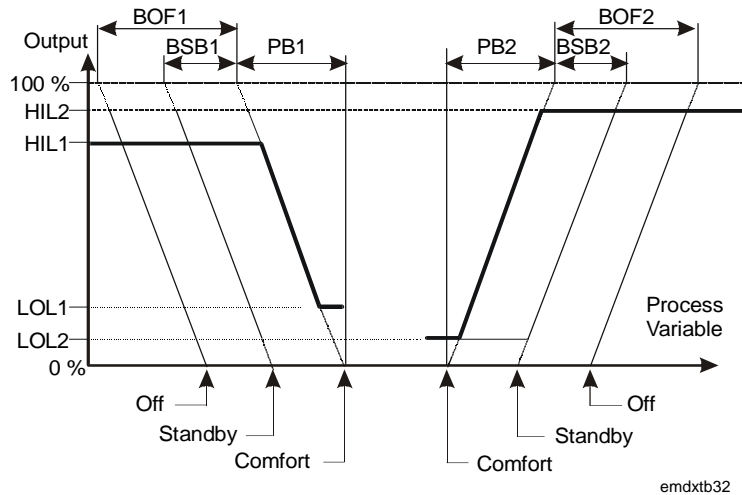

Figure 37: Heating/Cooling PID Module Operation

Loop Changeover (Versions 1.4, 2.4, 3.4, or Later)

A loop is active when the process variable is within the control range of the loop and loop changeover takes place midway between the two comfort, standby, or off setpoints, depending on the current mode. An option is available in later versions of the controller to set a configuration parameter, Enable Zero Output Changeover, which prevents loop changeover when the controller output is not at a zero value (or at its low limit value). This option avoids step changes in the controller output when the process variable changes rapidly between the heating and cooling setpoints.

Algorithm 4 - Heating/Cooling On/Off Control

Each of the 12 programmable function modules can be defined as a Heating/Cooling On/Off Control Module. The algorithm is implemented with two on/off control loops sharing the same Process Variable (PV) and output (OCM). For *Version 1.1 or later* of the DX-9100 controller, the output of the heating control loop (OCM1) and the output of the cooling control loop (OCM2) are also available. The algorithm generates an output of 0 or 1 by comparing the Process Variable (PV) with the Working Setpoint (WSP) and Action mode (ACT1/ACT2) for the respective loop.

During configuration, the Action mode (ACT1/ACT2) is entered as a positive or negative number. It determines the operating action of the respective loop. An ACT of +1 selects direct acting and an ACT of -1 selects reverse acting. For the normal heating/cooling functions, ACT1 is -1 and ACT2 is +1.

Control Module Inputs and Outputs

The Heating/Cooling On/Off algorithm can be configured by using a number of analog and logic variables. As part of its operating function, it also provides a number of logical outputs to be used for interlocking or alarm purposes. Below is a list of these variables:

Numeric Input Variable Connections

- **PV@** defines the source of the process variable. It is typically a pressure, temperature, or humidity input which, as it varies, causes the control module to change its output according to its On/Off function.
- **RV1@/RV2@** defines the source of the reference variable or ratio for the respective loop. This input causes the control module to perform as a ratio controller. Its effect is a multiplication factor in the working setpoint calculation. If not connected, a default value of 1 is assumed.
- **RS1@/RS2@** defines the source of a remote setpoint for the respective loop. This input produces a bias on the local setpoint LSP1/LSP2. If not connected, a default value of 0 is assumed.

Logic Input Variable Connections

- **OF@** defines the source of a digital input that forces the control module to the Off mode. If not connected, the Off mode is disabled.
- **SB@** defines the source of the digital input that puts the control module to the Standby mode. If not connected, the Standby mode is disabled.
- **RA@** defines the source of the digital input that causes the control module action to be reversed. If not connected, the control action change function is disabled.
- **EF@** defines the source of the digital input that forces the control module to the External Forcing mode. If not connected, the function is disabled.

Logic Output States

- **CMH**: Output of control module has reached its high limit. (Loop 1 or 2)
- **CML**: Output of control module has reached its low limit. (Loop 1 or 2)
- **HHDA**: High High Deviation Alarm. (PV - WSP) is greater than the high high deviation alarm value. (Loop 1 or 2)
- **HDA**: High Deviation Alarm. (PV - WSP) is greater than the high deviation alarm value. (Loop 1 or 2)

- **LDA:** Low Deviation Alarm. (WSP - PV) is greater than the low deviation alarm value. (Loop 1 or 2)
- **LLDA:** Low Low Deviation Alarm. (WSP - PV) is greater than the low low deviation alarm value. (Loop 1 or 2)
- **EF:** When this state is on, the module is being externally forced.
- **STA:** When this state is on, the module is in Startup mode.
- **SOF:** When this state is on, the module is in Shutoff mode.
- **HLD:** When this state is on, the module is in Hold mode.
- **CMP:** When this state is on, the module is in Computer mode.
- **OF:** When this state is on, the module is in Off mode.
- **SB:** When this state is on, the module is in Standby mode.
- **RA:** When this state is on, the module is in Reverse Action mode.
- **HEAT:** When this state is on, the module is in Heating mode.

Once the various inputs have been assigned to the control module, its operation will be determined using the following parameters for the respective loops:

- **LSP1/LSP2:** Local Setpoint. A value in the engineering unit of the PV (°C, °F, %, etc.) representing the basic setpoint of the control module. It is normally used to set the desired temperature, humidity, or pressure of the controlled zone.
- **ACT1/ACT2:** Action mode
- **DIF1/DIF2:** Differential. Used to set the differential for On/Off transitions.
- **BSB1/BSB2:** Standby Bias. Represents the shift of the WSP when the control module is operating in the Standby mode.
- **BOF1/BOF2:** Off Bias. Represents the shift of the WSP when the control module is operating in the Off mode. It normally represents the anti-condensation or night setpoint.
- **DHH1/DHH2:** Deviation High High Alarm Limit Value
- **DH1/DH2:** Deviation High Alarm Limit Value
- **DL1/DL2:** Deviation Low Alarm Limit Value
- **DLL1/DLL2:** Deviation Low Low Alarm Limit Value

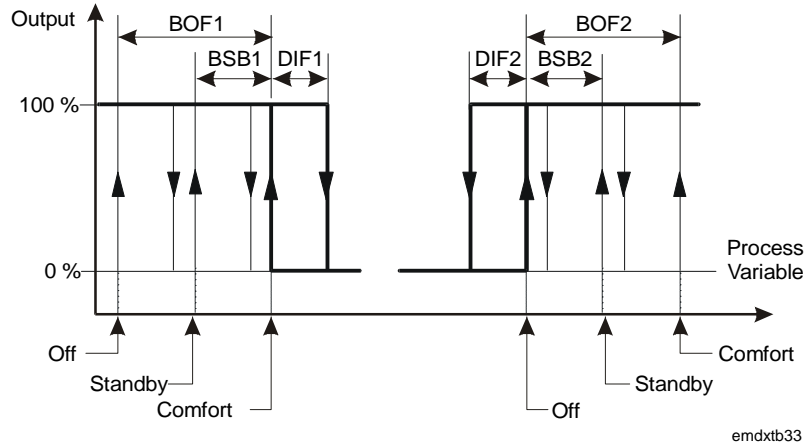

Figure 38: Heating/Cooling On/Off Module Operation

**Numeric
Calculation
Algorithms**

Each of the 12 programmable function modules can be defined as a numeric calculation module, capable of executing a mathematical algorithm. Each module can accept up to eight inputs from the controller’s numerical and logic variables and each module provides an output, which can be connected to either a control or output module, the appropriate interconnections being carried out during configuration. Each of the 12 programmable function modules can be configured to perform one of the following algorithms:

**Algorithm 11 -
Average
Calculation**

This algorithm calculates the arithmetic average of up to eight connected inputs. Each input may be weighted with a constant K.

$$\frac{(I1 \times K1 + I2 \times K2 + \dots + I8 \times K8)}{K0}$$

n = Input Variable n= 1 to 8
n = Constant n = 0 to 8

The module output (NCM) can be limited by a Low Limit (LOL) and a High Limit (HIL).

When the module is in Hold mode, its numeric output is not updated by the algorithm and can be modified by an FMS.

**Algorithm 12 -
Minimum Select**

This algorithm selects the minimum value of up to eight input variables. Each input may be weighted with a constant K.

$$\text{Output} = K_0 + \text{MIN.}(I_1 \cdot K_1, I_2 \cdot K_2, \dots, I_8 \cdot K_8)$$

$$I_n = \text{Input Variable} \quad n = 1 \text{ to } 8$$

$$K_n = \text{Constant} \quad n = 0 \text{ to } 8$$

The module output (NCM) can be limited by a Low Limit (LOL) and a High Limit (HIL).

When the module is in Hold mode, its numeric output is not updated by the algorithm and can be modified by an FMS.

**Algorithm 13 -
Maximum Select**

This algorithm selects the maximum value of up to eight input variables. Each input may be weighted with a constant K.

$$\text{Output} = K_0 + \text{MAX.}(I_1 \cdot K_1, I_2 \cdot K_2, \dots, I_8 \cdot K_8)$$

$$I_n = \text{Input variable} \quad n = 1 \text{ to } 8$$

$$K_n = \text{Constant} \quad n = 0 \text{ to } 8$$

The module output (NCM) can be limited by a Low Limit (LOL) and a High Limit (HIL).

When the module is in Hold mode, its numeric output is not updated by the algorithm and can be modified by an FMS.

**Algorithm 14 -
Celsius
Psychrometric
Calculation**

Three calculation functions are selectable in this algorithm, providing an output representing enthalpy, wet bulb temperature, or dew point temperature.

The output is a function of two inputs, one representing temperature and the other humidity. The units used are as follows:

- Enthalpy: kJ/kg
- Wet Bulb: °C
- Dew Point: °C
- Temperature: °C
- Humidity: %

The module output (NCM) can be limited by a Low Limit (LOL) and a High Limit (HIL).

When the module is in Hold mode its numeric output is not updated by the algorithm and can be modified by an FMS.

Algorithm 15 - Fahrenheit Psychrometric Calculation

Three calculation functions are selectable in this algorithm, providing an output representing either enthalpy, wet bulb temperature, or dew point temperature.

The output is a function of two inputs, one representing temperature, and the other humidity. The units used are as follows:

- Enthalpy: BTU/lb
- Wet Bulb: °F
- Dew Point: °F
- Temperature: °F
- Humidity: %

The module output (NCM) can be limited by a Low Limit (LOL) and a High Limit (HIL). When the module is in Hold mode, its numeric output is not updated by the algorithm and can be modified by an FMS.

Note: In *Version 1.1 or later* of the DX-9100, two enthalpy functions are provided in the psychrometric calculation modules. Each calculation has an output (NCM1, NCM2), can be limited by a low limit and a high limit, and can be put in Hold mode. Enthalpy switchover control (economizer control) can be achieved using the two enthalpy outputs and a comparator module. (See *Algorithm 21 - Comparator.*)

Algorithm 16 - Line Segment

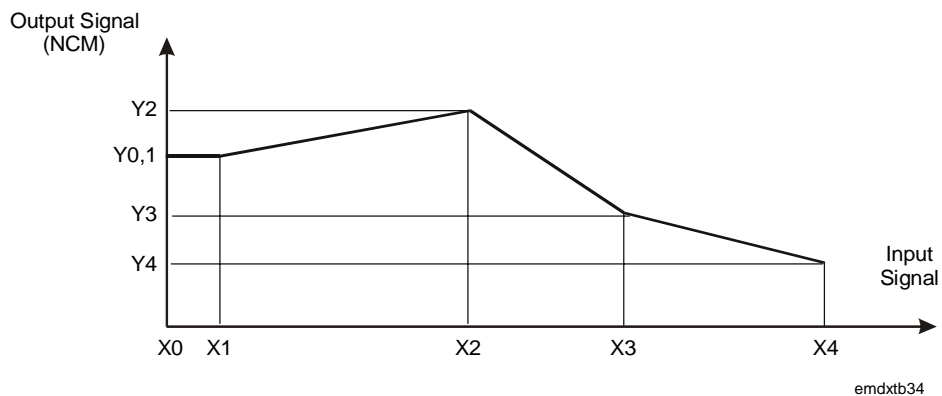

Figure 39: Example of a Line Segment Function

The output of this algorithm is a nonlinear function of the input defined on an x, y plane, using up to 17 break points (16 segments):

- Break Point 0: coordinates x0, y0
- Break Point 16: coordinates x16, y16

Notes: Values of the Output y for the complete range of the Input x must be defined. The module can be chained with the next programmable function module (in numerical sequence) to obtain up to 34 break point coordinates for 1 input.

When the module is in Hold mode, its numeric output (NCM) is not updated by the algorithm and can be modified by an FMS.

Algorithm 17 - Input Selector

This algorithm selects one of its four analog inputs (I1-I4) as its output. The selection is determined by the state of Digital Inputs I5 and I6.

Table 4: Algorithm 17 - Input Selector

Input	I5	I6	Output
I1	Off	Off	I1 x K1 + C1
I2	On	Off	I2 x K2 + C2
I3	Off	On	I3 x K3 + C3
I4	On	On	I4 x K4 + C4

In = Analog Input Variable n = 1 to 4

In = Logic Input Variable n = 5 and 6

Cn, Kn = Constants n = 1 to 4

The module output (NCM) can be limited by a Low Limit (LOL) and a High Limit (HIL). When the module is in Hold mode, its numeric output is not updated by the algorithm and can be modified by an FMS.

Algorithm 18 - Calculator

This algorithm provides two selectable functions, each of which is an algebraic expression of up to eight input variables.

Inputs, which are not connected, assume a default value of 1.

Equation 1 (Linear):

$$K0 + \frac{((K1 * I1 + K2 * I2 + K3) * I3 + K4) * I4}{((K5 * I5 + K6 * I6 + K7) * I7 + K8) * I8}$$

Equation 2 (Polynomial):

$$K0 + \frac{K1 * I1^3 + K2 * I2^2 + K3 * I3 * (K4 * I4 - K5 * I5) + K6 * \sqrt{I6} + K9}{K7 * I7 + K8 * I8}$$

In = Input Variable n = 1 to 8

Kn = Constant n = 0 to 9

The module output (NCM) can be limited by a Low Limit (LOL) and a High Limit (HIL). When the module is in Hold mode its numeric output is not updated by the algorithm and can be modified by an FMS.

**Numeric
Calculation
Algorithms for
Version 1.1 or
Later**

**Algorithm 23 -
Four Channel
Line Segment**

The following numeric calculation algorithms are available in the DX-9100-8154 controller with *Version 1.1 firmware* in the DX-9100-8454 or FA-DX9100-8454, *Version 2 controller*, and in the DX-912x-8454, *Version 3 controller*.

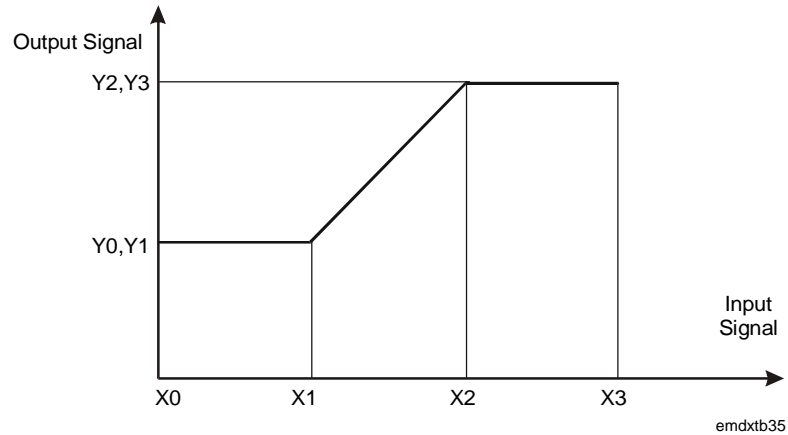

Figure 40: Example of a Line Segment Function

This algorithm comprises four line segment function channels, each defined by four break points (three segments).

- Break Point 0: coordinates x_0, y_0
- Break Point 3: coordinates x_3, y_3

Each channel has an input connection and an output (NCM1-NCM4), each of which may be put in Hold mode. When in Hold mode, the numeric output is not updated by the algorithm and can be modified by an FMS.

**Algorithm 24 -
Eight Channel
Calculator**

This algorithm provides eight calculator channels, each with two inputs, one output, and one of six mathematical functions:

- Addition $(K_1 \cdot I_1) + (K_2 \cdot I_2)$
- Subtraction $(K_1 \cdot I_1) - (K_2 \cdot I_2)$
- Multiplication $(K_1 \cdot I_1) \times (K_2 \cdot I_2)$
- Division $(K_1 \cdot I_1) / (K_2 \cdot I_2)$
- Minimum MIN $(K_1 \cdot I_1, K_2 \cdot I_2)$
- Maximum MAX $(K_1 \cdot I_1, K_2 \cdot I_2)$

I_1 = Input Variable 1

I_2 = Input Variable 2

K_1, K_2 = Constants

The module has eight outputs (NCM1-NCM8), one for each channel, each of which may be put in the Hold mode. When in Hold mode, the numeric output is not updated by the algorithm and can be modified by an FMS. The channels are independent and each may use any one of the available mathematical functions.

**Other
Functions**

**Algorithm 19 -
Timer Functions**

Each of the 12 programmable function modules can be configured to operate as a timer, providing an eight channel time delay unit. Each of the channels will have two inputs and provide one output, which can be connected to a control, logic, or output module. Each channel can be put in Hold mode and its logic output modified.

A channel can be configured to perform one of the following functions:

Pulse

The output goes high for a time period (T) after an input transition from low to high. Further transitions during the timing cycle do not influence the cycle. A 1 on the reset input forces the output to “0,” clearing the time cycle.

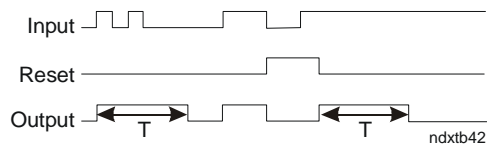

Figure 41: Pulse

Retriggerable Pulse

Similar to above, with the exception that the timing period begins from the last input transition. A 1 on the reset input forces the output to “0,” clearing the time cycle.

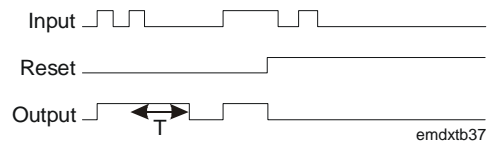

Figure 42: Retriggerable Pulse

On Delay with Memory

The output goes high after a time period (T) from the input going high. If the input is high for a period less than (T), the output never goes high. A 1 on the reset input is the only way to force the output to “0,” clearing the time cycle.

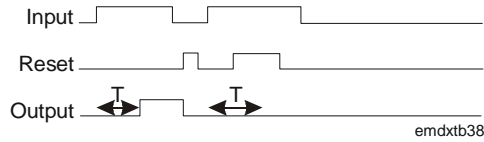

Figure 43: On Delay with Memory

On Delay

The output goes high after a time period (T) from the input going high. The output goes low when the input goes low. A 1 on the reset input forces the output to “0,” clearing the time cycle.

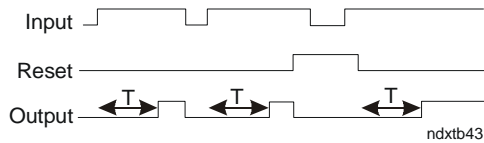

Figure 44: On Delay

Off Delay

The output goes high when the input goes high. The output goes low after a time period (T) from the input going low.

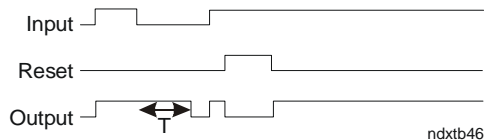

Figure 45: Off Delay

Algorithm 20 - Totalization

Each of the 12 programmable function modules can be defined as a totalization module, capable of executing a totalization algorithm. The algorithm has eight channels available. Each channel can be configured to perform one of the following functions:

- digital input event counter
- analog input integrator
- digital input time counter

Each channel has configurable inputs and provides one numeric output (TOT) as a result of the totalization function and a logic output (FSS) indicating that the numeric output has reached a programmed limit (FSL). Additionally, in *Version 1.1 and later*, each channel has an accumulator output (ACT), which may be set to count the number of times the totalization has reached its programmed limit and to automatically reset the channel. The accumulator output has a maximum value of 9,999,999 or 32,767 (15 bits) by configuration.

Each channel can be put in Hold mode. When in Hold mode, the numeric output is not updated by the algorithm and can be modified by an FMS.

Event Counter

This function performs the count of all transitions from 0 to 1 of a logic item connected to the input of the channel. The number of transitions is scaled to generate a numeric output. The event counter can be set to zero by a logic item connected to a reset input. When the output reaches a programmable full scale value, the counter full scale logic status is set and the output value remains at full scale until reset, or alternatively, the accumulator output is incremented and the channel reset to continue counting.

Integrator

This function performs the integration of the value of a numeric item connected to the input of the channel. The time constant determines integration rate. The integrator can be set to zero by a logic item connected to a reset input. When the output reaches a programmable full scale value, the integrator full scale logic status is set and the output value remains at full scale until reset, or alternatively, the accumulator output is incremented and the channel reset to continue integrating.

Time Counter

This function increases the value of the numeric output when the connected digital input is at 1. The output increase rate is a function of a time constant. The time counter can be set to zero by a logic item connected to a reset input. When the output reaches a programmable full scale value, the time counter full scale logic status is set and the output value remains at full scale until reset, or alternatively, the accumulator output is incremented and the channel reset to continue counting.

**Algorithm 21 -
Comparator**

Each of the 12 programmable function modules can be defined as a module with a comparator algorithm. The algorithm has eight channels available. Each channel performs the comparison of an analog input variable with a setpoint value and, by configuration, sets a logic status when the input value exceeds or alternatively falls below the setpoint value. The numerical value of the output is equal to the deviation. The setpoint value is either a configured constant or the value of a connected numerical variable.

Each channel can be individually put in Hold mode. When in Hold mode, the numeric output is not updated by the algorithm and can be modified by an FMS.

**Algorithm 22 -
Sequencer**

Each of the 12 programmable function modules can be configured as a sequencer providing the control of 1-8 logic outputs as a function of the value of an analog variable or 2 logic variables and the state of 8 logic (disable) inputs. The sequencer can be interfaced to the programmable logic control module and to other programmable function modules to provide interlocking and alarm capability.

Two consecutive sequencer modules can be linked together to control up to 16 outputs.

When an analog variable is connected, its value determines the required output in percent of the total output. When logic variables are connected, the first variable increases the required output value and the second variable decreases the output value.

The load factor for each output stage must be specified, and as a function of the total requested output the appropriate number of stages is activated. Whenever a stage is switched on or off, a delay timer is activated to prevent further stages being switched in rapid succession.

The difference between the requested output and the total activated output is available as a numeric variable for connection to other modules to provide proportional corrective control if required.

A **set** is a physical item of equipment, which requires set switching delay times to be entered independently of the stage switching delay times. For example, a set could be a refrigeration compressor, which has two stages. The switching delay times for the first stage of the compressor must be longer than for the second stage because in the first stage a large motor is being switched and in the second stage only a control valve on the compressor is being switched.

A special delay parameter is provided for the first set in the sequence and a limit value for the number of switching cycles in one hour for the set can be programmed.

A set is selected only if the disable logic input of the first stage of the set is not active. If the first stage is disabled when a set is running, the sequencer will automatically select another set.

The sequencer can be put in Hold mode. When in Hold mode, its required output value is not calculated by the algorithm and may be modified by an FMS.

Each sequencer module can be configured to operate in one of several modes:

- Step mode:** The output stages are controlled in sequence according to the “last on, first off” principle. For example, a three stage sequencer controls the output stages in the following sequence:

Stage	Increasing input >				Decreasing input >			
1	0	1	1	1	1	1	1	0
2	0	0	1	1	1	1	0	0
3	0	0	0	1	1	0	0	0

- Sequential:** The output sets are controlled in sequence according to the “first on, first off” principle. Stages within a set are controlled according to the “last on, first off” principle. For example, a three set sequencer controls the sets in the following sequence:

Set	Increasing input >				Decreasing input >			
1	0	1	1	1	1	0	0	0
2	0	0	1	1	1	1	0	0
3	0	0	0	1	1	1	1	0

- Equal Runtime:** The on time of the first output stage of each set is totaled. In case of an increase of load requiring the activation of a new set, the set with the lowest on time will be switched on. In case of a decrease of load requiring the switching off of a stage in a set at full load, the set with the highest on time will be switched off first. Stages within a set are always controlled to the “last on, first off” principle. For example, a three set sequencer controls the sets in the following sequence:

Set	Runtime	Increasing input >				Runtime	Decreasing input >			
1	90	0	0	0	1	95	1	1	1	0
2	40	0	1	1	1	110	1	0	0	0
3	65	0	0	1	1	99	1	1	0	0

- **Binary Code:** The output stages must form one set and are controlled in sequence according to a “binary code” principle. For example: a three stage sequencer controls the output stages in the following sequence:

Stage								
1	0	1	0	1	0	1	0	1
2	0	0	1	1	0	0	1	1
3	0	0	0	0	1	1	1	1

Increasing input >

Note: The Binary Code mode is designed for the control of electric heater batteries or other nonmechanical devices.

The binary code sequencer will always select the appropriate stage combination for the requested output, with a delay between the changing of a stage combination. The binary code sequencer will not step through successive combinations when a large change in the requested output occurs.

A Fast Step Down procedure causes the switching off of all the stages of all sets using a dedicated set of delays. The procedure is activated by a logic input, which cannot be interrupted until the switching-off sequence is completed. The Fast Step Down mode is automatically cleared when all the stages are off and the Fast Step Down input is off.

Programmable Logic Control

The DX-9100 operating system provides a software-implemented Programmable Logic Controller (PLC), which supports most of the functions available in dedicated PLCs. (Every second the PLC module executes a user-defined program, which references a memory area containing an image of the hardware digital inputs/outputs, logic variables from programmable function modules, logic result status variables, and digital constants required by the PLC program.) Variables in the memory area are frozen before the execution of the program in the PLC module, and the resulting changes in the logic variables are transferred out of the memory area to the appropriate hardware or function modules at the end of the module execution.

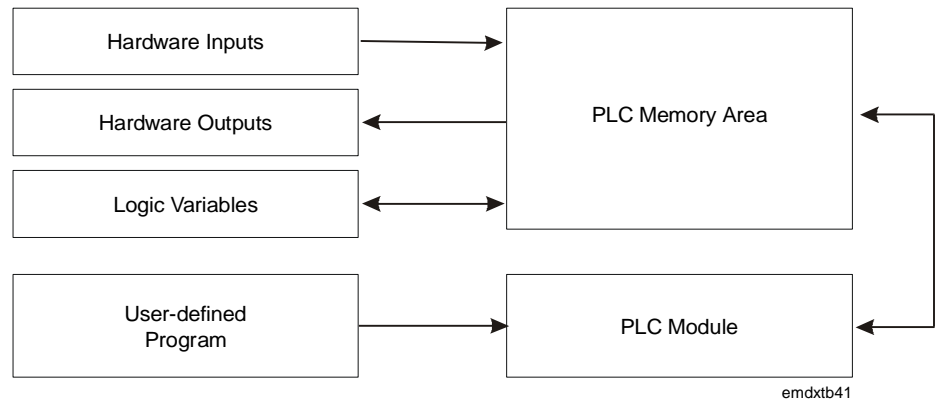

Figure 46: Programmable Logic Control

**PLC
User-Defined
Program**

A user-defined program is a sequence of instruction blocks and sub blocks, which contain logic instructions. Each instruction block has a result status, which is initialized by the first instruction of the block and transferred to the memory area by the final instruction of the block. When executing sub blocks, the PLC program creates a **partial result status**, which is logically combined with the **result status** at the end of the sub block.

In the GX-9100 Graphic Configuration software, the instructions are laid out in eight pages of ladder diagrams, each containing eight lines of up to eight instructions, graphically depicted as follows:

Instruction LOAD

This instruction begins an instruction block or logic sub block. A logic variable in the PLC memory area is referenced by the instruction and its status determines the **result status**. In the following diagram, the logic variable DI1 (Digital Input 1) is shown.

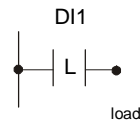

Figure 47: Load Instruction

Instruction LOAD NOT

This instruction begins an instruction block or logic sub block. A logic variable in the PLC memory area is referenced by the instruction and its inverse status determines the **result status**. In the following diagram, the logic variable AIH8 (high alarm status of Analog Input 8) is shown.

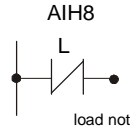

Figure 48: Load Not Instruction

Instruction AND

This instruction calculates a new **result status** using the Boolean AND operator. The status of a logic variable in the PLC memory area is referenced by the instruction. In the following diagram, the logic variable DI2 (Digital Input 2) is shown.

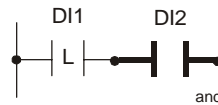

Figure 49: AND Instruction

Instruction AND NOT

This instruction calculates a new **result status** using the Boolean AND NOT operator. The status of a logic variable in the PLC memory area is referenced by the instruction. In the following diagram, the logic variable DI3 (Digital Input 3) is shown.

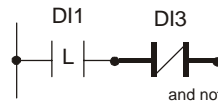

Figure 50: AND NOT Instruction

Instruction OR

This instruction calculates a new **result status** using the Boolean OR operator. The status of a logic variable in the PLC memory area is referenced by the instruction. In the following diagram, the logic variable DI4 (Digital Input 4) is shown.

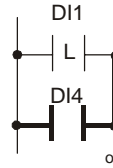

Figure 51: OR Instruction

Instruction OR NOT

This instruction calculates a new **result status** using the Boolean OR NOT operator. The status of a logic variable in the PLC memory area is referenced by the instruction. In the diagram, the logic variable DI5 (Digital Input 5) is shown.

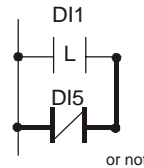

Figure 52: OR NOT Instruction

Instruction ANDB (AND Block)

This instruction calculates a new **result status** from the **partial result status** of the logic sub block and the **PLC result status**, which existed before the start (LOAD) of the sub block. The Boolean AND operator is used. No logic variable is referenced.

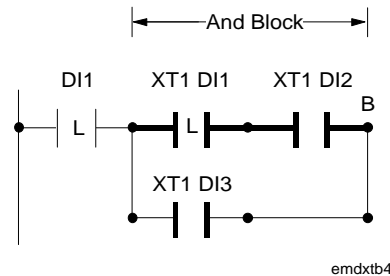

Figure 53: AND-Block Instruction

Instruction ORB (OR Block)

This instruction calculates a new **result status** from the **partial result status** of the logic sub block and the **PLC result status**, which existed before the start (LOAD) of the sub block. The Boolean OR operator is used. No logic variable is referenced.

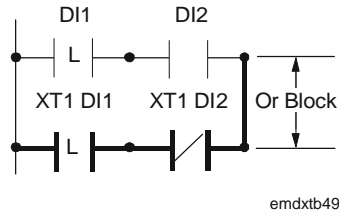

Figure 54: OR-Block Instruction

Note: OR Blocks may be nested within AND Blocks.

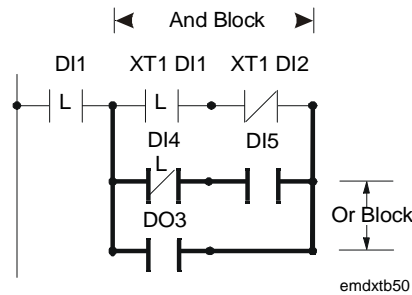

Figure 55: OR Block Nested Within AND Block

Instruction OUT

This instruction transfers the **result status** of the instruction block to the referenced logic variable in the PLC memory area. In this example, the result is transferred to the Logic Result Status Variable LRS1.

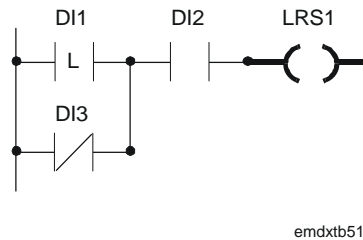

Figure 56: OUT Instruction

Instruction OUT NOT

This instruction transfers the inverse of the **result status** of the instruction block to the referenced logic variable in the PLC memory area. In this example, the result is transferred to the Logic Result Status Variable LRS2.

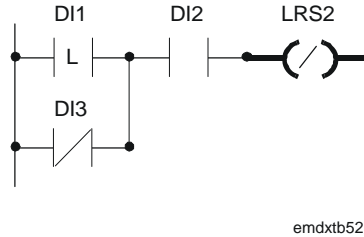

Figure 57: OUT NOT Instruction

Instruction COS

This instruction compares the PLC **result status** of the previous instruction in the logic block or sub block with the **result status**, which existed in the previous execution cycle of the PLC program. If the **result status** has changed from 0 to 1, the new **result status** is set to 1. Otherwise it is set to “0.” The instruction thus detects a positive “change of status.”

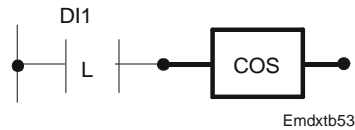

Figure 58: COS Instruction

Instruction SET

This instruction sets the status of the referenced logic variable in the PLC memory area to 1 if the PLC **result status** is true (1). Otherwise no action is taken. This instruction is conditional and operates only if the **result status** is true. In this example, the variable LRS3 will be set if the logic block result is true.

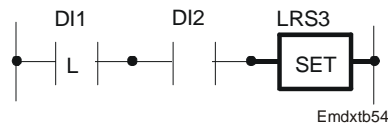

Figure 59: SET Instruction

Instruction RESET

This instruction resets the status of the referenced logic variable in the PLC memory area to 0 if the PLC **result status** is true (1). Otherwise no action is taken. This instruction is conditional and operates only if the **result status** is true. In this example, the variable LRS3 resets (set to 0) if the logic block result is true.

Note that normally each variable set by the PLC also needs to be reset by the PLC unless it is reset by some other module, by controller initialization, or by an FMS command.

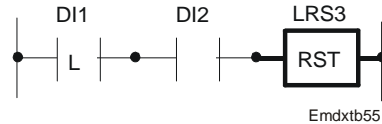

Figure 60: RESET Instruction

Instruction END

This instruction ends the execution of the user-defined program and sets the **result status** to the 0 state.

The next PLC execution cycle begins with the logic instruction in the specified address field. This allows the skipping of initialization routines in the lowest address locations.

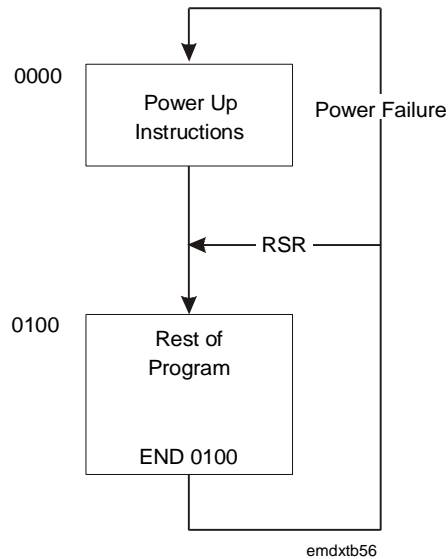

Figure 61: END Instruction

Instruction RSR

In the GX-9100 Graphic Configuration software, the “RSR” block marks the place where the PLC execution cycle begins when there has been no power failure.

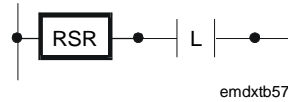

Figure 62: “RSR” Block

The PLC program is generated on the Graphic Configuration software. The program is laid out in the format of a ladder diagram and the GX Tool automatically generates the program code for the PLC module.

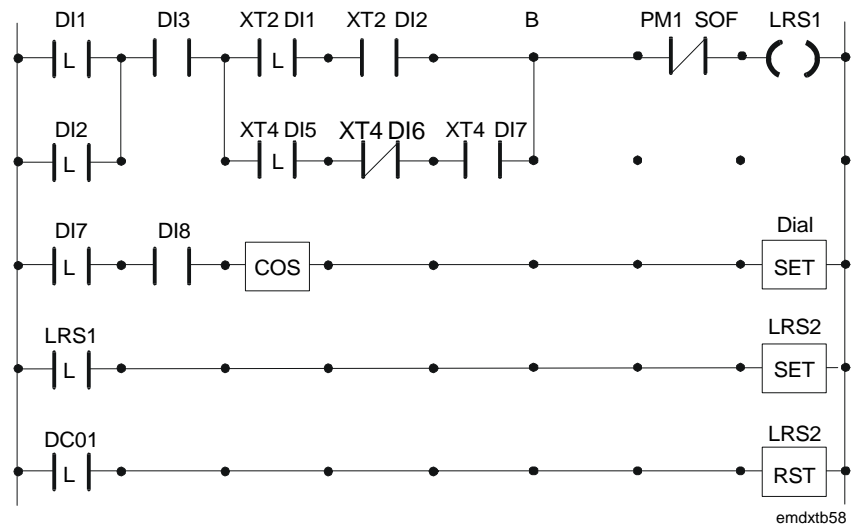

Figure 63: Example of a PLC Program

Dial-up Feature

The DX-9100, Versions 1 and 2 (with the Metasys N2 Bus Interface), can be used with a Metasys N2 Dialer Module (NU-NDM101-0) to establish a connection over a switch telephone line to an FMS installed at another location. The dial-up sequence is initiated when the N2 Dialer Module, which monitors the DX-9100 over the N2 Bus, finds that the logic variable DIAL has been set to 1. This variable is set within the PLC using COS and SET instructions and is reset by the FMS when the DX controller makes a successful connection. For further details, refer to the *LONWORKS N2E Bus Technical Bulletin (LIT-6364100)* and the *DX-9100 Configuration Guide (LIT-6364030)* found in this manual.

Note: This feature is only available with firmware Versions 1.2 and 2.1 or later, and is not available with the DX-912x LONWORKS version, Version 3.

**Power Up
Conditions**

Various options are available to determine power up conditions in the controller.

After a power failure, the following Hold modes may be set to hold, reset to Auto mode, or the mode before the power failure occurred can be retained:

- Analog Output Module Hold
- Logic Output Module Hold
- Programmable Function Module Hold
- Time Schedule Module Hold
- Optimal Start Module Hold

After a power failure, the following supervisory modes may be reset, or the mode before the power failure occurred can be retained:

- Startup mode
- Shutoff mode
- Digital Output Triac Override Enable

**Password
Feature
(Versions 1.4,
2.4, 3.4, or
Later)**

The password is used to protect a configuration when loaded into a controller. Once the password has been downloaded into the controller with the configuration, the controller will only allow a subsequent download or upload when the password is entered in the Download or Upload dialog box of the GX Software Configuration Tool. The password is encrypted by the GX Tool before download. If the password is lost and the user does not have access to the original configuration file which includes the password, then the controller must be returned to the supplier or the Johnson Controls factory to have the memory cleared. A password of 0 disables the protection feature.

- Notes:
1. The password feature is enabled by an entry in the gx9100.ini file of the GX Tool. The GX Tool software is delivered without this entry. Contact your local Johnson Controls sales office if you wish to enable the password feature in your GX Tool.
 2. This feature is only available with firmware Versions 1.4, 2.4, 3.4, or later. In older versions, the password feature was not implemented.

**Trend Log
Feature
(Versions 1.4,
2.4, 3.4, or
Later)**

The Trend Log module provides 12 trend log channels, each recording data from either 1 analog item or from a set of 8 logic variables. The trend can be used to provide data for Point History in DX controllers, which are remote from the Metasys Network or for a local DX LCD Display. Trend data cannot be displayed on the integral DX controller display panel, or on the GX or SX tools.

**Point History (for
DX Versions 1.4
and 2.4, or Later)**

When the DX controller is connected to a Metasys Network by an NDM dialer and telephone lines, the trend data may be read whenever a connection is made by the system. The data is stored in the Point History file of AI, AOS, BO, and BI objects when they are mapped to the items being recorded. When the Point History option is selected for a trend log channel, only those items which can be mapped to Metasys objects are allowed and the trend parameters are set by the GX Tool to recommend default values for the Point History feature. You must link the Historical Trend Read Request logic variable to the DIAL request logic variable in a PLC module to initiate a connection when a trend record buffer is full. Trend logs cannot be configured for Point History in a DX Version 3.x because they cannot be connected to an FMS by the NDM dialer and telephone lines.

**Trend Log for DX
LCD Display (for
DX Versions 2.4
and 3.4, or Later)**

Trend channels that are not used for Point History are freely configurable. For analog items, the sampling rate may be entered, and the stored values may be either the average, maximum, or minimum values during the sampling period, or the instantaneous value at the time of recording. Logic variables are recorded with a time and date stamp when there is a change of value. All channels may be displayed on the DX LCD Display.

Display Panel and Keypads

Front Panel Layout

Working parameters and values in the controller can be displayed, and in some cases modified, using the front panel. The panel layout consists of seven functional blocks that contain indicator LEDs and operating keys required to perform a variety of tasks.

DX-9100 Controller (Version 1)

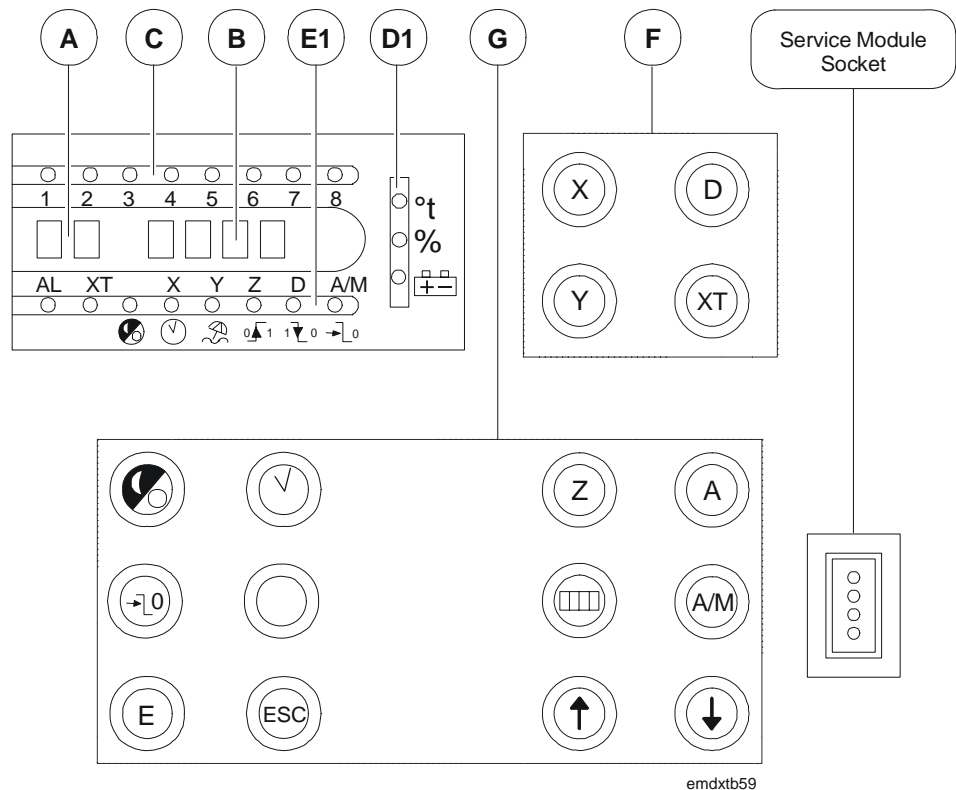
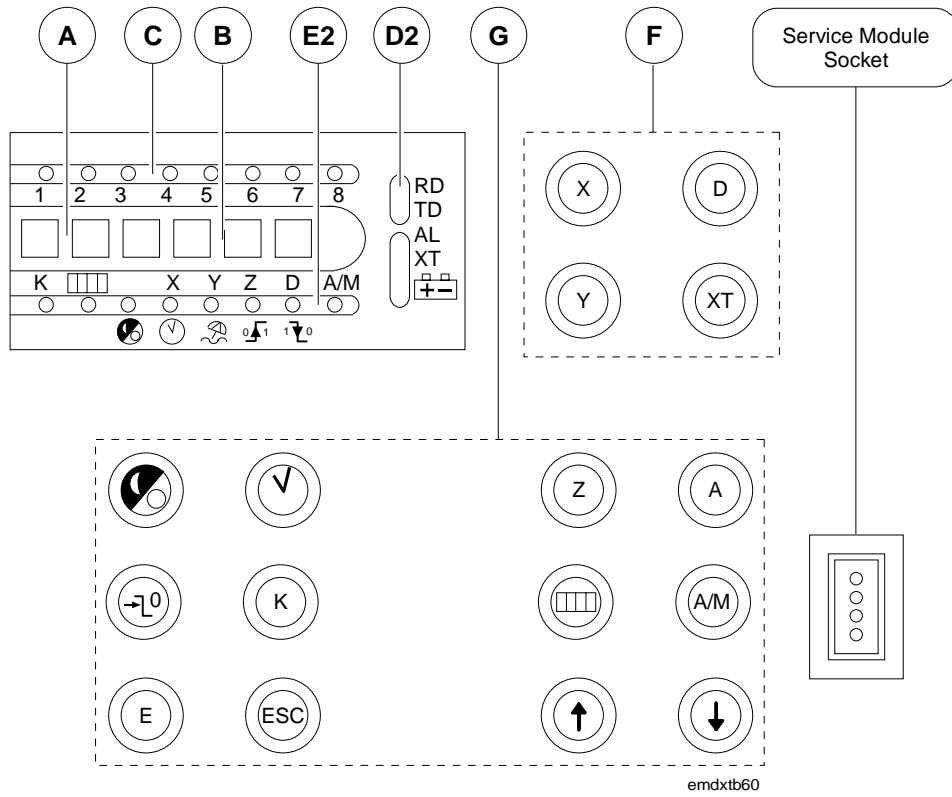

Figure 64: Front Panel Layout for Version 1 (DX-9100-8154)

**DX-9100
Controller
(Version 2)**



**Figure 65: Front Panel Layout for Version 2
(DX-9100-8454 or FA-DX9100-8454)**

**DX-9100
Controller
(Version 3)**

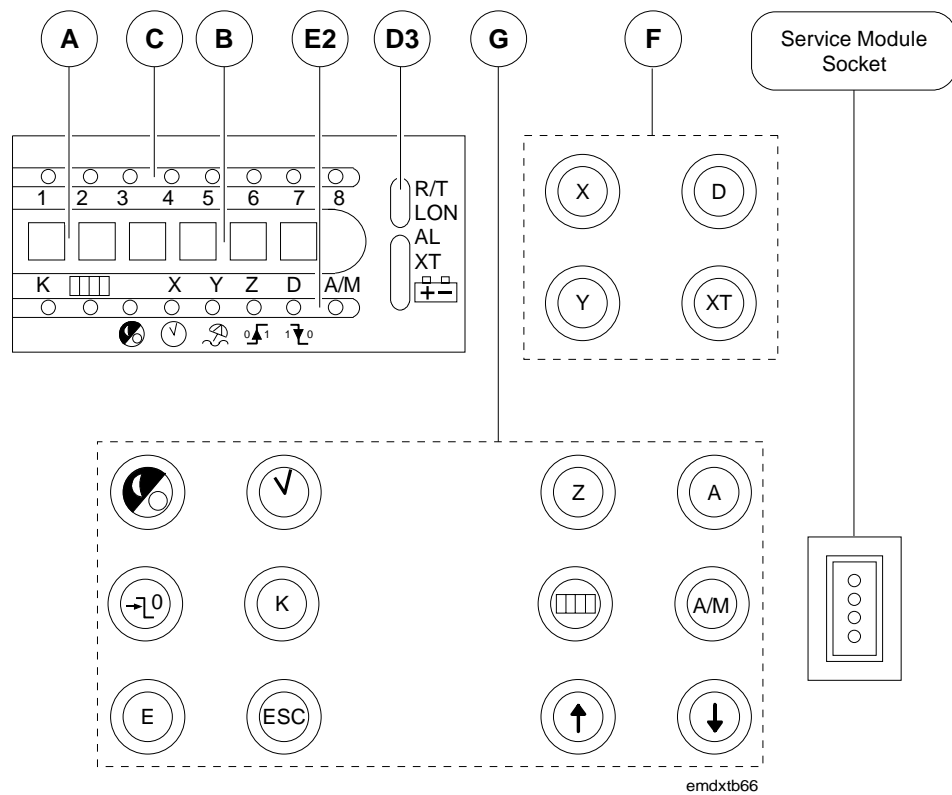

Figure 66: Front Panel Layout for Version 3 (DX-912x-8454)

Block Functions Block functions for all versions of the controller are outlined below.

Block A

Two 7-segment green LEDs show the **index number** of a selected Item.

Block B

Four 7-segment red LEDs monitor, display, and update the **value** of a selected Item:

- Analog inputs, outputs, and constants are indicated numerically.
- Digital inputs, outputs, and constants are indicated by the words On or Off.

Counter values of digital inputs and other totaled values are indicated numerically, showing units and thousands alternately.

Block C

Eight red LEDs indicate the status of **digital inputs** to the DX (or XT/XTM if selected in Block A), the **day of the week** in time schedule modules when in Time Schedule mode, and the **current day of the week** when in Realtime Clock mode.

Block D1 (Version 1)

Three red LEDs indicate the **units of measurement** in °t (°C or °F, as configured) or %. The  LED flashes when the internal **lithium battery** is due for replacement.

Block D2 (Version 2)

The two upper red LEDs indicate when data is being received (RD) on the N2 Bus (Bus 91) and when data is being transmitted (TD) by the DX-9100 controllers on the N2 Bus (Bus 91).

The lower three red LEDs indicate abnormal conditions:

- **AL** indicates that an analog input is in an **alarm** state.
- **XT** indicates a communication problem with the I/O **extension modules** (communication failure, XT/XTM hardware failure, or incorrect XP configuration).
-  flashes when the internal **lithium battery** is due for replacement.

Block D3 (Version 3)

The R/T red LED indicates when data is being received from or transmitted to the LONWORKS network processor. The red “LON” LED indicates the LONWORKS network processor activity, and will blink rapidly to indicate normal operation. If this LED is off, there is no communication with the LONWORKS N2 Bus network.

The lower three red LEDs indicate abnormal conditions:

- **AL** indicates that an analog input is in an **alarm** state.
- **XT** indicates a communication problem with the I/O **extension modules**.
-  flashes when the internal **lithium battery** is due for replacement.

Block E1 (Version 1)

Eight red LEDs indicate the selected Item or logic state.

AL indicates that an analog input is in an **alarm** state.

XT indicates a communication problem with the I/O **extension modules**.



indicates the **Time Scheduling** mode. When this LED is on, the remaining LEDs in this block indicate the following:



realtime clock display



exception day function selected



display of a **period begin** or **start time**



display of a **period end** or **stop time**



a time schedule module is in **Extension** mode

When the  LED is **off**, the remaining LEDs in this block indicate the following:

X selection of an **analog input**

Y selection of an **output module**

Z selection of a **programmable function module**

D selection of a **digital input**

A/M a control or output module is in **manual override**

Block E2 (Versions 2 and 3)

Eight red LEDs indicate the selected Item or logic state.

K indicates the selection of **analog or digital constants** for display.

 indicates the selection of **counter values** of digital inputs.

 indicates the **Time Scheduling** mode. When this LED is on, the remaining LEDs in this block indicate the following:

 **realtime clock** display

 **exception day** function selected

 display of a **period begin** or start time

 display of a **period end** or stop time

A/M a time schedule module is in **manual override**

Note: In *Versions 2 and 3*, the Extension mode of a time schedule module is indicated by a flashing display of the module status in Block B.

When the  LED is **off**, the remaining LEDs in this block indicate the following:

X selection of an **analog input**

Y selection of an **output module**

Z selection of a **programmable function module**

D selection of a **digital input**

A/M a control or output module is in **manual override**







Block F



Block F contains four operating keys for function selection.

- < X > selects **Analog Input** Display mode.
- < D > selects **Digital Input** Display mode.
- < Y > selects **Output Module** Display mode.
- < XT > selects **Input/Output** Display mode for extension modules.

Block G

Block G contains 12 operating keys for function selection. **These keys are concealed by the hinged cover during normal operation.**

- < Z > selects control module **Working Setpoint Display** mode.
- < A > is used to **advance** further information about the analog inputs, output modules, control module working setpoints, and time scheduling functions.
- <  > selects **Digital Input Counter** Display mode.
- < A/M > is used to select **automatic** or **manual** operation of the control, output, and time schedule modules.
- <  > **increases** the value of the selected Item or selects On.
- <  > **decreases** the value of the selected Item or selects Off.
- <  > selects the **Time Scheduling** mode.
- <  > selects the **Realtime Clock** mode.
- <  ₀ > **extension override** control sets the selected time schedule module to day **Extension** mode when the time schedule module is On. This is only possible when the time schedule module is On.
- < K > (*Versions 2 and 3*) selects Analog And Digital Constant Display mode.
- < E > selects the Edit mode for parameters and is used to confirm the entry of a new value.
- < Esc > is used to escape from Edit mode, ignoring the entry of a new value.

Note: To operate the < E >, < A/M >, <  >, and <  > keys, a special connector must be plugged into the service module socket.

Startup Mode

When the DX-9100 controller is first powered up or when power returns after an interruption, the following indications will be displayed in sequence during the startup period.

1. The red LED display will show `init` to indicate that the processor has started an initialization routine. All other LEDs will be turned on as an LED test function.
2. **Version 1.1 or later:** The red LED display will indicate the version number of the firmware.
3. **Version 1.1 or later:** If a configuration number has been entered into the DX-9100 database, the green LED display will show CF and the red LED display will show the configuration number.
4. **All versions:** Analog Input 1 will be displayed to indicate that the initialization routine is complete.
5. **Version 1.1 or later:** The eight analog inputs will be displayed successively, each value remaining for approximately three seconds. To stop the scrolling of analog values, press the `< ↓ >` key. To begin scrolling again, press the `< ↑ >` key.

Download Mode (Version 1.1 or Later)

When the DX-9100 is being downloaded by the GX Tool, the red LED display will show `halt` to indicate that all output operations have been suspended. At the end of the download, the GX Tool will command the DX-9100 to initialize as in *Startup Mode* above.

Time Schedule Mode

Press the `<  >` key once to select the Time Schedule mode.

- Time Schedule Module 1 will be shown via the green LED display.

Press the `<  >` key 2-8 times in succession to select and display Time Schedule Modules 2-8, respectively.

- The lighted red  LED indicates that the Time Schedule mode has been selected.
- The green LED display indicates the time schedule module number that has been selected.
- The red LED display shows the output status (On or Off) of the selected time schedule module.

Version 1

When the selected module is in extension override, the  LED is lit. When it flashes, another module is in extension override.

Versions 2 and 3

When the selected module is in extension override, the output status display will flash. The A/M LED indicates that the selected time schedule module is in Manual mode. When it flashes, another time schedule module is in Manual mode. When in Manual mode, the output of the module may be switched On or Off using the < ↑ > < ↓ > keys. Switching a module to Off will cancel the extension override, if it is active.

The < A > key is pressed to view information about the time schedule module. Press the < A > key once for a display of the **extension override time**.

- A lighted red  LED indicates the selection of Time Scheduling mode.
- The green LED display indicates the number of the time schedule module that has been selected.
- The red LED display shows the actual extension time in minutes (0-255).



Press the < A > key in succession for a display of programmed events, starting with Event Number 1. First the start time and then the stop time of each event is shown.

When the **start time** of an event is selected, the red  and $0^0 1^1$ LEDs are lit.

- The first digit of the green LED display indicates the time schedule module number (1-8).
- The second digit of the green LED display indicates the event number (1-8).
- The red LED display indicates the event starting time.
- Red LEDs 1-8 at the top of the front panel indicate for which days of the week the event is enabled. (1 = Monday, 2 = Tuesday, up to 8 = Holiday).

When the **stop time** of an event is selected, red  and $1^1 0^0$ LEDs are lit.

- The green LED display indicates time schedule module number and event number.
- The red LED display indicates the event stop time.
- The eight red LEDs 1-8 at the top of the front panel indicate for which days of the week the event is enabled. (1 = Monday, 2 = Tuesday, up to 8 = Holiday).

When the first non-programmed event is selected, the red  and  LEDs are lit.

- The green LED display indicates time schedule module number and event number.
- The red LED display shows the message “- - . - -”.

Press the < A > key to restart the selection of the time schedule module parameters from the time schedule output status.

Time Schedule Event Programming

A time schedule event is represented by the **extension time, start time, stop time, and days of the week** for which the event is enabled. It can be edited when the event is selected on the front panel.



Extension Time



The extension time is displayed and the red  LED is lit. Press the < E > key to select the extension time Edit mode.

- The red  LED on the front panel flashes.
- The green LED display indicates the time schedule module number.
- The red LED display shows the extension time in minutes (0-255).

Press the < ↑ > < ↓ > keys to modify the value of the extension time. Press the < E > key to save the value. Press the < Esc > key to restore the previous value and cancel the Editing mode.

Start Time

Start time is indicated via lighted red  and  LEDs. Press the < E > key to select the Edit mode of the event start time.

- On the front panel the red  LED flashes and the  LED is lit.
- The green LED display indicates the time schedule module number and event number.
- The red LED display indicates the start time in hour.minute format.

Press the < ↑ > < ↓ > keys to modify the start time value.

To clear the event, modify the start time to 00.00 and then press the < ↓ > key again.

- A cleared event is indicated with the message “- - . - -”.

The resulting gap in the time schedule is automatically filled with the higher indexed events.

Press the < Esc > key to restore the previous value and cancel the event Editing mode.

Press the < E > key to save the modified start time and for stop time editing access.

Stop Time

- On the front panel, the red  LED flashes and the ¹LED⁰ LED is lit.
- The green LED display indicates time schedule module number and event number.
- The red LED display indicates the stop time in hour.minute format.

Press the < ↑ > < ↓ > keys to modify the stop time value.

Press the < Esc > key to restore the previous value and cancel the event Editing mode.

Days of the Week

Pressing the < E > key saves the modified stop time and gives access to the next step in which the days of the week for the command can be edited.

- On the front panel, the red  LED flashes and LEDs 1-8 indicate for which days of the week the event is enabled.
- The green LED display shows the time schedule module number and event number.
- The red LED display indicates the day of the week selected (1-8).

Press the < ↑ > < ↓ > keys to enable or disable, respectively, the event for the selected day.

This action will immediately update the status of the corresponding red LED in the upper display, and the number representing the next day of the week will appear.

Press the < A > key to advance without changing the status.

Press the < Esc > key to restore the previous days of week selection and cancel the event Editing mode.

Press the < E > key to save the modified day enabling conditions.



Realtime Clock Calendar

The <  > key selects the Realtime Clock mode and the successive selection and display of:



- Realtime and Date
- Exception Days Schedule (Holidays)
- Daylight Saving Dates

Realtime and Date Mode



Initially press the <  > key once to select the Realtime **Clock** mode. On the front panel:

- The red  and  LEDs are lit, indicating that the Realtime and Date mode has been selected.
- The green LED display shows the character **t**.
- The red LED display shows the realtime in the hour.minute format.
- The upper row of red LEDs show the day of the week (1-7) and whether the current day is a holiday (8).

Press the < A > key in the Realtime mode to select the **date**. On the front panel:



- The red  and  LEDs are lit, indicating that the Realtime and Date mode has been selected.
- The green LED display shows the characters **d.t**.
- The red LED display shows the actual date in the “month.day” format.

Press the < A > key in the Actual Date mode to select the **year**. On the front panel:

- The red  and  LEDs are lit, indicating that the Realtime and Date mode has been selected.
- The green LED display shows the characters **y.r**.
- The red LED display shows the actual year.

The realtime and date can be modified when displayed on the front panel. Press the < E > key to select the Edit mode.

- The front panel shows the  LED flashing and the  LED lit.

Press the <  > <  > keys to modify the realtime or date.







Press the < Esc > key to restore the previous time.

Press the < E > key to save the modified time or date.

Press the <  > key while in Realtime and Date mode to select the Exception Days Schedule mode.





Exception Days Schedule Mode

The Exception Days (Holidays) Schedule mode can be reached from the Realtime and Date mode by pressing the <  > key. On the front panel:

- Lighted red , , and  LEDs indicate that the Exception Days Schedule mode has been selected.
- The red ⁰¹ or ¹⁰ LEDs indicate whether a period begin or period end date is selected.
- The green LED display shows the exception day period index, from 01-32.
- The red LED display shows the value of the first exception period begin date in the “month.day” format.





An exception day period, normally describing a holiday period, is defined by a begin date and an end date.



Press the < A > key in succession to view all the programmed exception day periods.

- The ⁰¹ LED indicates the begin date and ¹⁰ LED indicates the end date.
- The first location not programmed will be indicated by the message “- - . - -”.

The exception days period can be programmed when the period begin date is selected on the front panel. The procedure begins and is advanced with the < E > key and is aborted with the < Esc > key.

Initially press the < E > key once to select the Edit mode of the **period begin date**.

- The front panel shows the red  LED flashing, and the , , and ⁰¹ LEDs are lit.
- The green LED display shows the exception day period index.
- The red LED display shows the begin date in the “month.day” format.

Press the <  > <  > keys to modify the **begin date**.





The period can be cleared by modifying the begin date to “01.01” and pressing the <  > key.

- A cleared period is indicated with the message “- - . - -”.

The resulting gap in the Exception Days Schedule is automatically filled with the higher indexed periods.

The < Esc > key restores the previous value and cancels the exception day Edit mode.

Pressing the < E > key saves the modified begin date and gives access to the editing of the **end date**.

- The front panel shows the red  LED flashing and the , , and ¹₀ LEDs are lit.
- The green LED display shows the exception day period index.
The red LED display shows the end month and day in the “month.day” format.

Press the < ↑ > < ↓ > keys to modify the end date.



Press the < Esc > key to restore the previous value and cancel the exception day Edit mode.

Press the < E > key to save the modified end date. Press the < A > key for access to the next exception day period.



Press the <  > key in the Exception Days mode to select the Daylight Saving mode.

Daylight Saving Dates Mode

A daylight saving period is defined by a begin date and an end date and can be reached from the Exception Days Schedule mode by pressing the <  > key. On the front panel:

- The red ,  and ⁰₁ LEDs are lit.
- The green LED display shows the message dL.
- The red LED display shows the daylight saving begin date in the “month.day” format.

Press the < E > key to select the Edit mode of the begin date. On the front panel:

- The red  LED flashes and the  and ⁰₁ LEDs are lit.
- The green LED display shows the message dL.
- The red LED display shows the daylight saving begin date in the “month.day” format.



Press the < ↑ > < ↓ > keys to modify the begin date.

The daylight saving can be disabled by modifying the start date to “01.01” and pressing the < ↓ > key.

- This will be indicated with the message “- - . - -”.

The < Esc > key restores the previous value and cancels the Daylight Saving mode.

Pressing the < E > key saves the modified begin date and gives access to the editing of the end date. On the front panel:

- The red  LED flashes, and the  and ¹ LEDs are lit.
- The green LED display shows the message dL.
- The red LED display shows the daylight saving end date in the “month.day” format.

Press the < ↑ > < ↓ > keys to modify the end date.

Press the < Esc > key to restore the previous value and cancel the daylight saving Editing mode.

Press the < E > key to save the modified end date.

Press the <  > key in the Daylight Saving mode to select the Realtime and Date mode.

Analog Input Display Mode

Press the < X > key to select the Analog Input Display mode and Analog Input 1 will appear. Press the < X > key in succession to select and display Analog Inputs 2-8.

- A lighted red X LED indicates that the Analog Input Display mode has been selected.
- The green LED display indicates the analog input number that has been selected.
- The red LED display shows the measured value of the analog input.
- **Version 1:** The red LED in Block D indicates the unit of measurement.

Note: In **Version 2**, the units of measurement LEDs have been replaced by N2 Bus transmission indicators RD and TD. In **Version 3**, they have been replaced by R/T and LON.

If the analog input reading is outside the alarm limits, the red **AL** LED will be lit.

If the **AL** LED flashes, then another analog input of the DX-9100 controller has exceeded its alarm limits.

Press the < A > key to view the high and low alarm limits that correspond to each of the analog inputs.

- The green LED display shows the parameter selected as L for low limit and H for high limit.
- The red LED display shows the value of the limit selected.

Press the < E > key, followed by the < ↑ > < ↓ > keys to modify the high and low limits.

- During the Edit mode the **X** LED flashes.

Press the < E > key to confirm a change. Press the < Esc > key to restore the previous value.

When XT/XTM extension modules are connected, providing additional analog inputs, press the < XT > key while in the Analog Input Display mode to view the corresponding analog inputs.

- The first digit of the green LED display indicates the extension module (1-8).
- The second digit of the green LED display indicates analog input (1-8).

If the analog input reading is outside the alarm limits, the red **AL** LED will be lit. If the **AL** LED flashes, then another analog input of the selected XT/XTM extension module is outside its alarm limits. Press the < X > key in succession to select and display all analog inputs in each module.

Press the < A > key to view high and low alarm limits that correspond to each of the extended analog inputs.

Press the < E > key, followed by the < ↑ > < ↓ > keys to modify the high and low limits. Press the < E > key to confirm a change. Press the < Esc > key to restore the previous value.

Analog Input Scroll Mode

When in the Analog Input Display mode, the Analog Input Scroll mode may be selected by pressing the < ↑ > key. In this mode, the analog inputs will be displayed successively with each value remaining for approximately three seconds. The analog inputs are displayed as described under *Analog Input Display Mode*. To stop the scrolling of analog values, press the < ↓ > key. The Analog Input Scroll mode operates for the eight analog inputs of the DX-9100 or for the four, six, or eight analog inputs of any connected XT/XTM extension module. After a power failure, the Analog Input Scroll mode is automatically started for the eight analog inputs of the DX-9100 controller.

Digital Input Display Mode

Initially press the < D > key once to select the Digital Input Display mode and view Display Digital Input 1. Press the < D > key in succession to select and view display Digital Inputs 2-8.

- The red D LED is lit, which indicates that the Digital Input Display mode has been selected.
- The green LED display shows the digital input number selected.
- The red LED display shows the states of the digital inputs.

When XT/XTM extension modules are connected, providing additional digital inputs, press the < XT > key while in the Digital Input Display mode to view related digital inputs.

- The first digit of the green LED display indicates the extension module (1-8).
- The second digit of the green LED display indicates digital input (1-8).

Press the < D > key in succession to select and display all digital inputs in each extension module.

Note: When an XT/XTM extension module has 16 digital inputs, the input values are displayed under 2 consecutive XT numbers. The <D> key is used to display all 16 inputs in sequence.

Output Module Display Mode

Press the < Y > key once to select the Output Module Display mode and view Output Module 1. Press the < Y > key in succession to select and Display Output Modules 2-8.

- A lighted red Y LED indicates that the Output Module Display mode has been selected.
- The green LED display shows the output module number selected.
- The red LED display shows the measured value of the output module as follows:

Table 5: Output Module Values

Output Module Type	Indication Range
Analog (0-10V or 0/4-20 mA)	0-100%
Digital - On/Off (Logic source)	On or Off
Digital - On/Off (Numeric source)	0-100%
Digital - DAT	0-100%
Digital - PAT without Feedback	0-100%
Digital - PAT with Feedback	0-100%
Digital - Start/Stop	On or Off
Digital - Pulse	On or Off

Note: Only those outputs that have been defined in the DX-9100 controller configuration are displayed. On/off outputs must also have a connection to determine whether the source is logic or numeric. When the connection is numeric, the output is Off when the value is 0 or less, and On for any value greater than 0.

Version 1: The red LED in Block D will indicate % as the unit of measurement.

Notes: In **Version 1**, Output Modules 1 and 2 are analog outputs, while Output Modules 3-8 are logic type outputs.

In **Versions 2 and 3**, Output Modules 1, 2, 9-14 are analog outputs, while Output Modules 3-8 are logic type outputs.

When XT/XTM extension modules are connected and providing additional outputs, press the < XT > key while in the Output Display mode to view the outputs.

- The first digit of the green LED display indicates the extension module (1-8).
- The second digit of the green LED display indicates the output (1-8).

Press the < Y > key in succession to select and view all outputs in each extension module.

Note: When an XT/XTM extension module has 16 digital outputs, the output values are displayed under 2 consecutive XT numbers, but the <Y> key is used to display all 16 outputs in sequence.

To distinguish between Analog Outputs 11-14 and Outputs 1-4 on XT1, the first digit of the green LED will show a small 1 for Analog Outputs 11-14.



Figure 67: LEDs Showing Analog Outputs 11-14

Press the < A > key to view information about the output modules.

- If the output module is connected to the OCM output of a control algorithm, the red LED display will indicate Cnn where “nn” is the number of the control module (1-12).
- If the output is connected to another variable, the message “- -” appears in the red LED display.

Press the < A/M > key to switch the output module or XT output into Manual mode.

- A lighted red A/M LED indicates that the output module is in Manual Operating mode.
- A flashing red A/M LED indicates that another output module in the DX-9100 or XT output in the selected XT is in the Manual Operating mode.

Press the < ↑ > < ↓ > keys to increase or decrease the module output. For a logic output, the state will change from On to Off.

Press the < A/M > key again to switch the output module to Automatic mode.

Notes: Output modules may be overridden from an FMS by placing the module into Hold (Manual) mode. The override condition is indicated by a lighted red A/M LED when the module value is displayed, and the Hold mode may be reset by pressing the < A/M > key.

The triac outputs used by digital output modules may be directly overridden from an FMS, in which case there is no indication at the DX front panel and the override condition cannot be reset.

Digital Counter Display Mode

Press the < [] > key to select the Digital Input Counter Display mode and view the counter value for Digital Input 1. Press the < [] > key in succession to display counter values for Digital Inputs 2-8.

- **Version 1:** A lighted red D LED indicates that the Digital Input Display mode has been selected.
- **Versions 2 and 3:** A lighted red [] LED indicates that the Digital Input Counter Display mode has been selected.
- The green LED display shows the digital input number that has been selected.
- The red LED display shows the counter value via two numbers, which are displayed alternately. The number preceded by a “.” is the units value of the counter (0.000 - 0.999). The other number is the thousands value of the counter (0000 - 9999). The actual counter value is obtained by placing the two numbers together (0000000 - 9999999). Depending on the configuration, the counter value may reset at 32767.

When XT/XTM **extension modules** are connected, providing additional digital inputs, press the < XT > key while in the Digital Counter Display mode to view the corresponding digital counters.

- The first digit of the green LED display indicates the extension module (1-8).
- The second digit of the green LED display indicates the digital input (1-8).

Press the <  > key in succession to select and view all digital counter values in each extension module.

Press the < E > key followed by the < ↑ > < ↓ > keys to modify the counter value.

Press the < E > key to enter the modified value or press the < Esc > key to restore the previous value.

**Programmable
Function
Module Display
Mode**

Operating values and parameters for control, totalization, and sequencer algorithms can be viewed and modified from the front panel.

- Press the < Z > key to select the Programmable Function Module Display mode and view values and parameters for the first module.

Press the < Z > key in succession to view the values and parameters for the other programmable function modules that have been configured as control, totalization, or sequencer modules.

Control Modules

A lighted red Z LED indicates that the Working Setpoint Display mode has been selected.

The green LED display shows the control module number selected. If the control module is a heating/cooling (dual) PID or On/Off module, the control module number and loop number are displayed alternately. The heating loop working setpoint is displayed first with a flashing “L1.” Press the < A > key to view the cooling loop working setpoint with a flashing “L2.”

The red LED display shows the working setpoint value for the selected control module.

- **Version 1:** The red LED in Block D shows the units of measurement.

Press the < E > key, followed by the < ↑ > < ↓ > keys, to modify the local setpoint of the selected control module. This, in turn, modifies the working setpoint displayed.

During the Edit mode the Z LED flashes. To confirm the modification, press the < E > key. To restore the previous value, press the < Esc > key.

Note: The working setpoint may only be adjusted within the minimum and maximum values entered into the control module database.

Press the < A > key to view auxiliary information on the working setpoint.

Press the < A > key to view the **process variable** value for the selected control module.

The red Z LED is lit and the red X LED flashes.

Press the < A > key a second time to view the **output** of the selected control module.

The red **Z** LED is lit and the red **Y** LED flashes.

Press the < A/M > key to switch the control module to **Manual** mode.

- A lighted red A/M LED indicates that the control module is in the Manual mode.
- A flashing red A/M LED indicates that another control module is in the Manual mode.

Press the < ↑ > < ↓ > keys to increase or decrease control module output.

Press the < A/M > key again to switch the control module back to Automatic mode.

PID Control Modules

Press the < A > key in succession to view further parameters as follows:

- **Proportional band** (flashing “P,” “P1,” or “P2” in the green LED display).
- **Reset action** in repeats/minute (flashing “i,” “i1,” or “i2” in the green LED display).
- **Rate (derivative) action decay time** in minutes (flashing “d,” “d1,” or “d2” in the green LED display).
- **Standby bias** (flashing “b,” “b1,” or “b2” in the green LED display).
- **Off bias** (flashing “o,” “o1,” or “o2” in the green LED display).

On/Off Control Modules

The following parameters can be modified on the On/Off Control Modules:

- Control action (flashing “A,” “A1,” or “A2” in the green LED display).
- Differential (flashing “d,” “d1,” or “d2” in the green LED display).
- Standby bias (flashing “b,” “b1,” or “b2” in the green LED display).
- Off bias (flashing “o,” “o1,” or “o2” in the green LED display).

Press the < E > key, followed by the < ↑ > < ↓ > keys, to increase or decrease the parameters displayed. Press the < E > key to save the modified value, or press the < Esc > key to restore the previous value.

Totalization Modules

A lighted red **Z** LED and a flashing red **Y** LED indicate that the **Totalization Module Output Value Display** mode has been selected.

- The green LED display shows, alternately, the programmable function module number selected and the totalization module channel number “t1.”
- The red LED display shows the totaled value for the selected module and Channel 1.
- Press the < A > key to view the totaled output values of Channels 2-8.
- The green LED display shows, alternately, the programmable function module number selected and the totalization module channel number “t2,” “t3,” up to “t8.”
- The red LED display shows the totaled value for the selected module and channel.

Whenever a totaled value is being displayed, the < A/M > key may be pressed to set the channel to **Manual** mode.

- A lighted red A/M LED indicates that the channel is in the Manual mode.
- A flashing red A/M LED indicates that another module or channel is in the Manual mode.

Press the < ↑ > < ↓ > keys to increase or decrease (reset to 0, for example) the totaled value.

Press the < A/M > key again to set the channel back to Automatic mode. The totaled value set in Manual mode will be maintained as the initial value for the continuing totaling operation.

Special Option for Totalization Channel Accumulator

If any channel has been configured with the **accumulator** option, the total accumulated value for this channel will be displayed after the display of the totaled value (t1-t8) when the < A > key is pressed.

The green LED display alternately show the programmable function module number selected and the totalization module channel number are displayed as “A1” to “A8” to indicate the accumulated value.

The red LED display shows the accumulated value for the selected module and channel. Two numbers flash alternately. The number preceded by a “.” represents units and the other number represents thousands of units. An accumulated value of up to 9999999 is displayed with the two alternate displays of “9999” and “.999.” Depending on the configuration, the accumulated value may reset at 32767.

Whenever an accumulated value is being displayed, press the < E > key to edit the value or to reset it to 0.

- A flashing **Z** LED indicates **Edit** mode.

Press the < ↑ > < ↓ > keys to modify the displayed value.

Press the < E > key to enter the modified value or the < Esc > key to retain the original value.

Note: The DX-9100 controller automatically increments the **accumulated** value each time the **totaled** value reaches a configured limit. In this case the totaled value may be regarded as a fine resolution (or a “vernier scale”) for the accumulated value.

Sequencer Module

A lighted red **Z** LED and a flashing red **Y** LED indicate that the **Sequencer Module Requested Output Value** Display mode has been selected.

- The green LED display shows the programmable function module number selected.
- The red LED display shows the requested output value for the selected module.

Press the < A/M > key to set the module to Manual mode.

- A lighted red A/M LED indicates that the module is in the Manual mode.
- A flashing red A/M LED indicates that another module is in the Manual mode.

Press the < ↑ > < ↓ > keys to increase or decrease the output value.

Press the < A/M > key again to set the module back to Automatic mode.

Press the < A > key to view the **totaled run time** (in hours) of the sets in the selected sequencer module.

- The green LED display shows the sequencer stage number of the first stage in each set with an “r” prefix for single digit numbers.
- The red LED display shows the totaled runtime value via two numbers which are displayed alternately. The number preceded by a “.” is the units value of the runtime (.000 - .999). The other number is the thousands value of the runtime (0000 - 9999). The full runtime value is obtained by placing the two numbers together (0000000 - 9999999).

Press the < E > key, followed by the < ↑ > < ↓ > keys, to modify the runtime value displayed (reset to 0, for example). Press the < E > key to save the modified value, or press the < Esc > key to restore the previous value.

Press the < A > key to successively view and modify the runtime values of all sets in the module.

Press the < E > key, followed by the < ↑ > < ↓ > keys, to increase or decrease the parameters displayed. Press the < E > key to save the modified value, or press the < Esc > key to restore the previous value.

**Analog/Digital
Constant
Display Mode**

Versions 2 and 3 only: Press the <K> key to select the Analog/Digital Constant Display mode.

- A lighted red K LED indicates that the Analog/Digital Function Display mode has been selected.

Press the <K> key in succession to view the eight analog constants followed by the digital constants.

Press the <E> key followed by the < ↑ > < ↓ > keys to modify the selected analog or digital constant.

During the Edit mode, the K LED flashes. Press the < E > key to save the modified value, or press the < Esc > key to restore the previous value.

Note: Changes made to analog and digital constants will remain until another change is made from the front panel or from an FMS. The originally downloaded values can only be restored by a new download.

Specifications and Technical Data

Table 6: Specifications

Supply Voltage	24 VAC, ±15%, 50-60 Hz <i>Version 1:</i> To maintain an active sensor supply ≥ 15 VDC, the supply voltage must always exceed (24 VAC - 10%).	
Power Consumption	10 VA (nominal) at 50/60 Hz	
Ambient Operating Conditions	0 to 40°C (32 to 104°F) 10 to 90% RH non-condensing	
Ambient Storage Conditions	-20 to 70°C (4 to 160°F) 5 to 95% RH	
Internal Batteries	Lithium. Shelf life (disconnected): 10 years Working life, with 24V power: 5 years; without 24V power: ≤ 1 year Rechargeable backup battery. Recharge time is one hour; capacity is seven days when fully charged.	
Processor	<i>All Versions:</i> NEC 78C10	<i>Additional in Version 3:</i> Neuron® 3150 (Three CPUs)
Memory:	<i>All Versions:</i> 8 Kb RAM 56 Kb EPROM 8 Kb EEPROM	<i>Additional in Version 3:</i> 32 Kb ROM 26 Kb RAM 512 Byte EEPROM
Terminations	Terminal block for 1 x 1.5 mm ² /14 AWG (maximum) cable	
Serial Interfaces	<p><i>Versions 1 and 2:</i> One optically isolated RS 485 interface for N2 connection; 9600 baud</p> <p><i>Versions 2 and 3:</i> One RS-232-C port; 9600 baud</p> <p><i>DX9120 Version 3.0 to 3.4:</i> One TP78 transceiver LONWORKS Bus interface; 78K baud. (Maximum of thirty controllers on one N2 LONWORKS Bus.)</p> <p><i>DX9121 Version 3.4:</i> One FTT10a transceiver LONWORKS Bus interface; 78K baud. (Maximum of thirty controllers on one N2 LONWORKS Bus.)</p> <p><i>All Versions:</i> One optically isolated RS-485 interface for XT Bus connection; 9600 baud</p> <p><i>All Versions:</i> One interface for service module; 600 baud</p>	
Continued on next page . . .		

Specifications (Cont.)	
Analog Inputs	<p>Eight inputs, 13-bit resolution. Inputs selectable, via jumper, for 0-10 VDC (300K minimum impedance), 0/4-20 mA (100 ohm impedance) or RTD (Ni1000, Pt1000, A99)</p> <p>Version 1: Active sensor supply: 15 VDC, 100 mA for maximum of four current transmitters (20 mA). To maintain an active sensor supply \geq 15 VDC, the supply voltage must always exceed (24 VAC - 10%).</p> <p>Versions 2 and 3: Active sensor supply: 15 VDC, 200 mA for maximum of eight current transmitters (0/4-20 mA). Maximum of 80 mA may be used for voltage transmitters.</p>
Digital Inputs	<p>Eight inputs via potential-free contacts</p> <p>Transition counter function: maximum 10 Hz (>50 ms closed, >50 ms open)</p>
Analog Outputs	<p>Eight Bit Resolution</p> <p>Version 1: Two outputs, selectable via jumper for 0-10 VDC (maximum 10 mA) or 0/4-20 mA (maximum 500 ohm)</p> <p>Versions 2 and 3: Four outputs, selectable via jumper for 0-10 VDC (maximum 10 mA) or 0/4-20 mA (maximum 500 ohm). Four additional outputs 0-10 VDC (maximum 10 mA)</p>
Digital Outputs	Six triac outputs, 24 VAC, 0.5 ampere continuous (0.8 ampere peak)
Realtime Clock	Time in hours and minutes. Date in year, month, day. Automatic calendar for day of week (1-7). Daylight saving time change at defined dates.
Scheduling Modules	Eight time schedule modules, each with eight events; two optimal start/stop modules
Exception Days	Thirty exception day (holiday) periods defined by begin and end dates
Programmable Function Modules	<p>Twelve modules, each configurable for:</p> <ul style="list-style-type: none"> • PID Controller • On/Off Controller • Heating/Cooling PID Controller • Heating/Cooling On/Off Controller • Average Calculation • Minimum/Maximum Selection • Psychrometric Calculation (Celsius/Fahrenheit) • Line Segment Function (16-segment or 4 x 4-segment) • Input Selector • Calculator (Linear or Polynomial Equation) • Timer Functions (Eight Channels) • Totalization (Event, Integration, Runtime) (Eight Channels) • Comparator (Eight Channels) • Sequencer (Up to Eight Output Stages, Sixteen Stages by Chaining) • Simple Calculator (Eight Channels)
Continued on next page . . .	

Specifications (Cont.)	
Programmed Logic Control	<p>PLC module executing Boolean functions:</p> <ul style="list-style-type: none"> • AND/AND NOT • OR/OR NOT • ANDB (AND-Block) • ORB (OR-Block) • OUT/OUT NOT • COS (Change-of-State) • SET/RESET <p>Maximum of 512 instructions (on GX Tool, eight pages with eight lines of up to eight instructions)</p>
Network Inputs/Outputs	<p>Version 3 only: Sixteen analog inputs. Eight blocks of sixteen digital inputs. Sixteen analog outputs, each with sixteen network destinations. Eight blocks of sixteen digital outputs, each block with sixteen network destinations. (Maximum of thirty controllers on one LONWORKS N2 Bus.)</p>
Program Execution Cycle	<p>DX-9100: I/O, Programmable Function Modules, PLC - 1 second XT Bus: Digital I/O only or up to four XT-9100s - 1 second XT Bus: More than four XT-9100s with analog I/O - 2 seconds</p>
Housing	<p>Material: ABS + polycarbonate, self-extinguishing VO UL 94 Protection: IP30 (IEC529)</p>
Dimensions (H x W x D)	<p>Version 1 Controller: 148 x 184 x 81mm (5.8 x 7.3 x 3.2 in.) Controller with Panel Mounting Base, Versions 2 and 3: 200 x 184 x 95 mm (7.9 x 7.3 x 3.8 in.). Allow minimum of 160 mm (6.3 in.) depth for hinged door clearance. Controller with Cabinet Door Mounting Frame, Versions 2 and 3: 164 x 200 x 114 mm (6.5 x 7.9 x 4.5 in.)</p>
Shipping Weight (Maximum)	<p>Controller: 0.8 kg (1 lb 12 oz) Panel Mounting Base: 0.8 kg (1 lb 12 oz) Cabinet Door Mounting Frame: 0.8 kg (1 lb 12 oz)</p>
Agency Listings	<p>UL916 Listed and CSA Certified FCC Part 15 - Subpart B (Class A Device) CE Directive 89/336/EEC:</p> <ul style="list-style-type: none"> • EN50081/1, EN50082/1 <p>Terminal cover required on DX panel mounting base (supplied with mounting base DX-9100-8997 and DX-9121-8997) when the DX controller is not installed inside a metal cabinet.</p>

**Products
Available in
North America**

Table 7: Controller and Accessories (North America)

Code	Description
DX-9100-8454	Extended Digital Plant Controller, Version 2
FA-DX9100-8454	Extended Digital Plant Controller, Version 2 (Facilitator)
DX-9100-7454	Extended Digital Plant Controller, Version 2 Repair Module
FA-DX9100-7454	Extended Digital Plant Controller, Version 2 Repair Module (Facilitator)
DX-9120-8454	Extended Digital Plant Controller, Version 3 (LONWORKS TP78)
DX-9120-7454	Extended Digital Plant Controller, Version 3 (LONWORKS TP78) Repair Module
DX-9121-8454	Extended Digital Plant Controller, Version 3 (LONWORKS FTT10a)
DX-9121-7454	Extended Digital Plant Controller, Version 3 (LONWORKS FTT10a) Repair Module
DX-9100-8990	Panel Mounting Base for Controller, Versions 2 and 3 (LONWORKS DX-9120 TP78), without terminal covers
DX-9100-8991	Terminal Cover Kit for Panel Mounting Base
DX-9100-8996	Cabinet Door Mounting Frame for Controller, Versions 2 and 3 (LONWORKS TP78)
DX-9121-8997	Panel Mounting Base for Controller, Version 3 (LONWORKS FTT10a)
DX-9121-8996	Cabinet Door Mounting Frame for Controller, Version 3 (LONWORKS FTT10)
AS-LCPKEY-0	Security Key (US) for Front Panel Operation
SX-9120-8110	Service Module (North American)
SX-9120-8912	Service Module Firmware Upgrade Kit
DX-9100-8911	Controller, Version 1, Firmware Upgrade
DX-9100-8913	Controller, Version 2, Firmware Upgrade
FA-DX91-8913	Controller, Version 2, Firmware Upgrade (Facilitator)
DX-9120-8911	Controller, Version 3, Firmware Upgrade
MW-MTOOL	Configuration Tools Software
FA-WINPRO-0	Configuration Tools Software (Facilitator)
DEMO-DX120	Demo Case, DX-9100 (120 V) Version 2
DEMO-FDX120-2	Demo Case, DX-9100 (120 V) Version 2 (Facilitator)
DEMO-DX120-3	Demo Case, DX-9121* (120 V) Version 3 (FTT10)
NU-NET201-0	N2E LONWORKS Network Card for NCMs - TP78 Network
NU-EOL201-0	End-of-Line Termination Module - TP78 Bus (DX-9120)
NU-NET202-0	N2E LONWORKS Network Card for NCMs - FTT10 Network
NU-EOL202-0	End-of-Line Termination Module – FTT10 Bus (DX-9121)
DC-9100-6800	Replacement Lithium Battery

Table 8: XT/XP Ordering Codes (North America)

Code	Description
XT-9100-8304	Extension Module
XP-9102-8304	Expansion Module (6 AI, 2 AO)
XP-9103-8304	Expansion Module (8 DO – Triacs)
XP-9104-8304	Expansion Module (4 DI, 4 DO – Triacs)
XP-9105-8304	Expansion Module (8 DI)
XP-9107-8304	Expansion Module (4 DO – Relay) (North American) 24 V only

Table 9: XTM-905/XPx-xxx-x Ordering Codes (North America)

Code	Module Type	Description
XTM-905-5	Extension Module	Communications interface and 24 VAC supply
XPA-821-5	Expansion Module Analog	6 analog inputs 2 analog outputs without manual override
XPB-821-5	Expansion Module Binary	8 binary inputs
XPL-401-5	Expansion Module Binary	4 binary inputs 3 binary outputs (latching relays with manual override)
XPE-401-5	Expansion Module Binary	4 binary inputs 3 binary outputs (electrically maintained relays with manual override)
XPE-404-5	Expansion Module Binary	4 binary inputs 4 binary outputs (common supply) (On/Off or pulse relays with manual override)
XPT-401-5	Expansion Module Binary	4 binary inputs 4 binary outputs (24 VAC triacs with manual override)
XPT-861-5	Expansion Module Binary	8 binary outputs (24 VAC triacs without manual override)
XST-101-0		Blank Stickers for Module Front Panels: Pack of 50 sheets, DIN A4, 12 stickers per sheet, laser printable

**Products
Available in
Europe**

Table 10: Controller and Accessories Ordering Codes (Europe)

Code	Description
DX-9100-8154	Extended Digital Plant Controller, Version 1
DX-9100-7154	Extended Digital Plant Controller, Version 1 Repair Module
DC-9100-8905	Security Key (European) for Front Panel Operation
DC-9100-6800	Replacement Lithium Battery
SX-9120-8101	Service Module
MW-MTOOLE-0	M-Tool Software, English Language, European Version
DEMO-DX230	Demo Case, DX-9100 (230 V) Version 2
DEMO-DX230-3	Demo Case, DX-9121* (230 V) Version 3 (LONWORKS FTT10)

Table 11: XT/XP Ordering Codes (Europe)

Code	Description
XP-9106-8304	Expansion Module (4 DO - Relay) (European)
TR-9100-8101	230/24 V Transformer 12 VA

Table 12: XPx-xxx-x Ordering Codes (Europe)

Code	Module Type	Description
XPA-421-5 XPA-431-5	Expansion Module Analog	4 analog inputs (including PT100, Ni100, and 0-5K ohm)
XPA-442-5 XPA-452-5	Expansion Module Analog	4 analog outputs with manual override
XPA-462-5 XPA-472-5	Expansion Module Analog	4 analog outputs without manual override
XPA-831-5	Expansion Module Analog	6 analog inputs 2 analog outputs without manual override
XPB-831-5	Expansion Module Binary	8 binary inputs
XPM-401-5 XPM-411-5	Expansion Module Binary	4 binary inputs 2 binary outputs (momentary relays with manual override)
XPL-411-5	Expansion Module Binary	4 binary inputs 3 binary outputs (latching relays with manual override)
XPL-421-5 XPL-431-5	Expansion Module Binary	4 binary inputs 3 binary outputs (latching relays without manual override)
XPE-411-5	Expansion Module Binary	4 binary inputs 3 binary outputs (electrically maintained relays with manual override)
XPE-421-5 XPE-431-5	Expansion Module Binary	4 binary inputs 3 binary outputs (electrically maintained relays without manual override)
XPE-414-5	Expansion Module Binary	4 binary inputs 4 binary outputs (common supply) (On/Off or pulse relays with manual override)
XPE-424-5 XPE-434-5	Expansion Module Binary	4 binary inputs 4 binary outputs (common supply) (On/Off or pulse relays without manual override)
XPE-444-5 XPE-454-5	Expansion Module Binary	4 binary outputs (common supply) (On/Off or pulse relays with manual override)
XPE-464-5 XPE-474-5	Expansion Module Binary	4 binary outputs (common supply) (On/Off or pulse relays without manual override)
XPT-411-5	Expansion Module Binary	4 binary inputs 4 binary outputs (24 VAC triacs with manual override)
XPT-421-5 XPT-431-5	Expansion Module Binary	4 binary inputs 4 binary outputs (24 VAC triacs without manual override)
XPT-871-5	Expansion Module Binary	8 binary outputs (24 VAC triacs without manual override)
Note: The model numbers with a 0, 2, 4, or 6 as the second digit are for modules with normal terminals; the model numbers with a 1, 3, 5, or 7 as the second digit are for modules with disconnect terminals.		

Appendix A: LONWORKS N2E Bus Poll Estimation Worksheet

The hardware on a Metasys Network allows up to thirty DX-912x controllers to be connected to an N2E Bus. However, some configurations using more than five DX-912x controllers on one bus may result in a slower system performance for monitoring functions than in an equivalent N2 Bus system. Determine the probable performance of your system by calculating the number of messages processed by the NCM per second. This varies depending on the NCM software configuration and on how many controllers are installed on one N2E Bus. The ideal message rate is at or below 1.5 messages per second. If the system has a higher rate than this, consider reducing the number of controllers or reconfiguring the NCM data base to make for a more efficient system. Control processes can be moved from GPL to the DX controllers, for example, using peer-to-peer communication for processes covering more than one controller.

Use the *LONWORKS N2E Bus Poll Estimation Worksheet* to calculate the message rate generated by a particular NCM configuration.

LONWORKS N2E Bus Poll Estimation Worksheet

Number of DXs (poll priority should be set to 3 for N2E applications) *93 msg/h = _____

Number of AIs with warning limits defined *120 msg/h = _____

Number of ADs mapped to CS attributes *120 msg/h = _____

Number of BDs mapped to CS attributes *900 msg/h = _____

Number of AIs with point history *2 msg/h = _____

Number of AOs with local control and point history *2 msg/h = _____

Number of ACMs *60 msg/h = _____

Total number of displayed CS attributes, AIs and AOs with local control typically displayed on all OWS/OT/NTU (average):

Number of OWS/OT/NTU _____ *number of points _____ *180 msg/hr = _____

Number of AI alarm events per hour = _____

Number of attributes read by JC-BASIC/GPL processes or Metalink® per hour = _____

Average number of scheduled commands per hour = _____

Average number of MCO commands per hour = _____

Number of trend samples per hour = _____

Sum of all messages per hour = _____

÷ 3600

Sum of all messages per second = _____

(The message rate should **not** exceed 1.5 msg/sec.)

The message rate of 180 messages per hour for AI and AO objects with local control must be adjusted if the refresh time parameters SummaryUpdate and GraphicsUpdate are changed from a default of 20 in the METASYS.INI file. See the *LONWORKS N2E Bus Technical Bulletin (LIT-6364100)* for more information and instructions about this process.

Notes

Notes



Controls Group
507 E. Michigan Street
P.O. Box 423
Milwaukee, WI 53201

www.johnsoncontrols.com
Printed in U.S.A.